

## Up to PL e of EN ISO 13849-1 PNOZ X1P



Safety relay for monitoring E-STOP pushbuttons

### Unit features

- ▶ Positive-guided relay outputs:
  - 3 safety contacts (N/O), instantaneous
  - 1 auxiliary contact (N/C), instantaneous
- ▶ Connection options for:
  - E-STOP pushbutton
  - Reset button
- ▶ LED indicator for:
  - Switch status channel 1/2
  - Supply voltage
- ▶ Plug-in connection terminals (either spring-loaded terminal or screw terminal)

### Safety features

- The relay meets the following safety requirements:
- ▶ The circuit is redundant with built-in self-monitoring.
  - ▶ The safety function remains effective in the case of a component failure.
  - ▶ The correct opening and closing of the safety function relays is tested automatically in each on-off cycle.

### Approvals

	PNOZ X1P
	◆
	◆
	◆

### Unit description

The safety relay is not suitable for non-contact barriers because

- ▶ a dynamic start is not possible
- The safety relay meets the requirements of EN 60947-5-1, EN 60204-1 and VDE 0113-1 and may be used in applications with
- ▶ E-STOP pushbuttons
  - ▶ Safety gates

### Block diagram

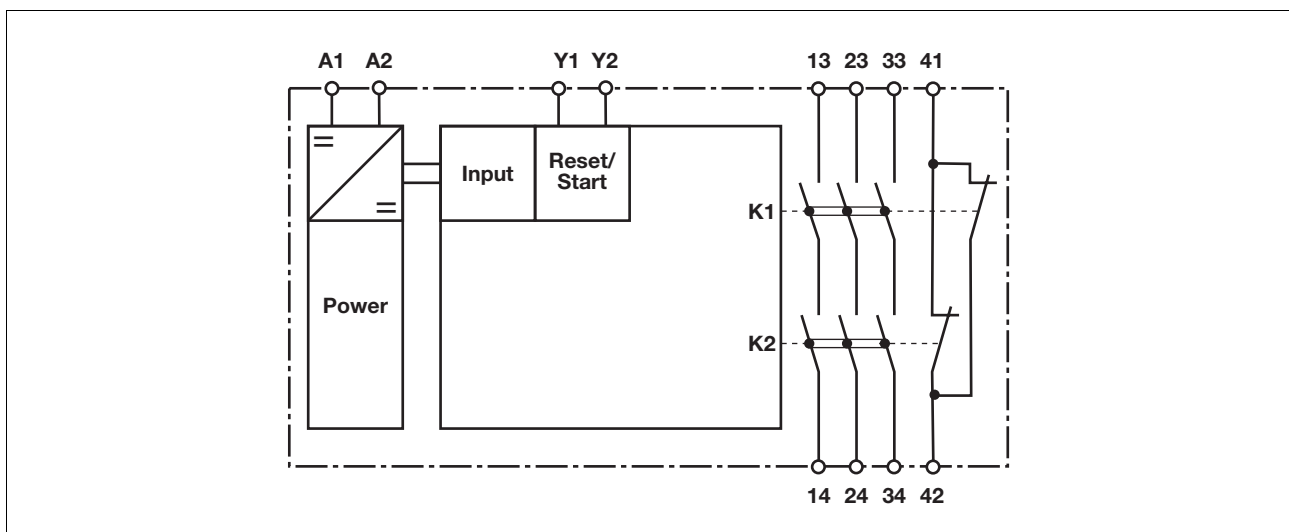

## Up to PL e of EN ISO 13849-1 PNOZ X1P

### Function description

- ▶ Single-channel operation: no redundancy in the input circuit, earth faults in the reset circuit are detected.
- ▶ Automatic start: Unit is active once the input circuit has been closed.
- ▶ Manual reset: Unit is active once the input circuit is closed and then the reset circuit is closed.
- ▶ Increase in the number of available instantaneous safety contacts by connecting contact expansion modules or external contactors.

### Timing diagram

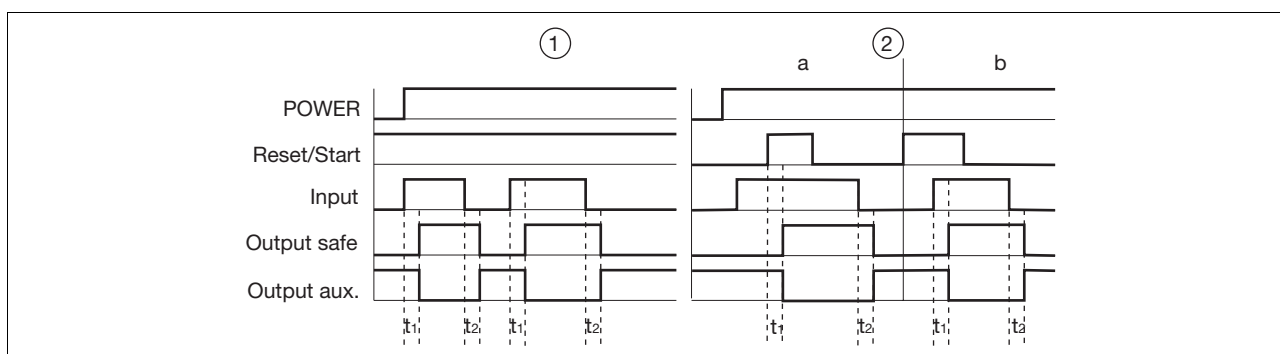

### Key

- ▶ Power: Supply voltage
- ▶ Reset/start: Reset circuit Y1-Y2
- ▶ Input: Input circuits A1
- ▶ Output safe: Safety contacts 13-14, 23-24, 33-34
- ▶ Output aux: Auxiliary contacts 41-42
- ▶ ①: Automatic reset
- ▶ ②: Manual reset
- ▶ a: Input circuit closes before reset circuit
- ▶ b: Reset circuit closes before input circuit
- ▶ t<sub>1</sub>: Switch-on delay
- ▶ t<sub>2</sub>: Delay-on de-energisation

### Wiring

Please note:

- ▶ Information given in the “Technical details” must be followed.
- ▶ Outputs 13-14, 23-24, 33-34 are safety contacts, output 41-42 is an auxiliary contact (e.g. for display).
- ▶ To prevent contact welding, a fuse should be connected before the output contacts (see technical details).
- ▶ Calculation of the max. cable runs  $I_{max}$  in the input circuit:

$$I_{max} = \frac{R_{I_{max}}}{R_l / km}$$

$R_{I_{max}}$  = max. overall cable resistance (see technical details)  
 $R_l / km$  = cable resistance/km

- ▶ Use copper wire that can withstand 60/75 °C.
- ▶ Sufficient fuse protection must be provided on all output contacts with capacitive and inductive loads.

## Up to PL e of EN ISO 13849-1 PNOZ X1P

### Preparing for operation

#### ▶ Supply voltage

Supply voltage	AC	DC

#### ▶ Input circuit

Input circuit	Single-channel	Dual-channel
E-STOP <b>without</b> detection of shorts across contacts		
Safety gate <b>without</b> detection of shorts across contacts		

#### ▶ Reset circuit



Reset circuit	E-STOP wiring (single-channel) Safety gate (single-channel)	E-STOP wiring (dual-channel) Safety gate (dual-channel)
Automatic reset		
Manual reset		

#### ▶ Feedback loop

Feedback loop	Automatic reset	Manual reset
Contacts from external contactors		

## Up to PL e of EN ISO 13849-1 PNOZ X1P

► Key

S1	E-STOP pushbutton
S3	Reset button
	Switch operated
	Gate open
	Gate closed

## Up to PL e of EN ISO 13849-1 PNOZ X1P

### Terminal configuration

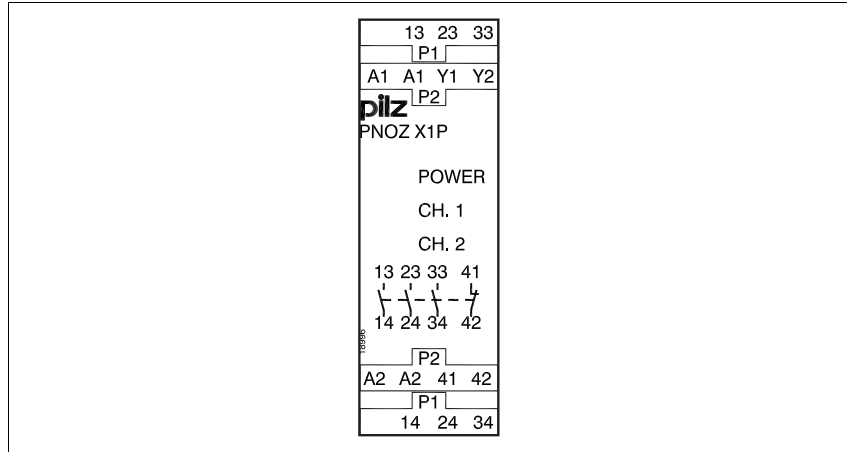

### Installation

- ▶ The safety relay should be installed in a control cabinet with a protection type of at least IP54.
- ▶ Use the notch on the rear of the unit to attach it to a DIN rail.
- ▶ Ensure the unit is mounted securely on a vertical DIN rail (35 mm) by using a fixing element (e.g. retaining bracket or an end angle).

### Dimensions

\* with spring-loaded terminals

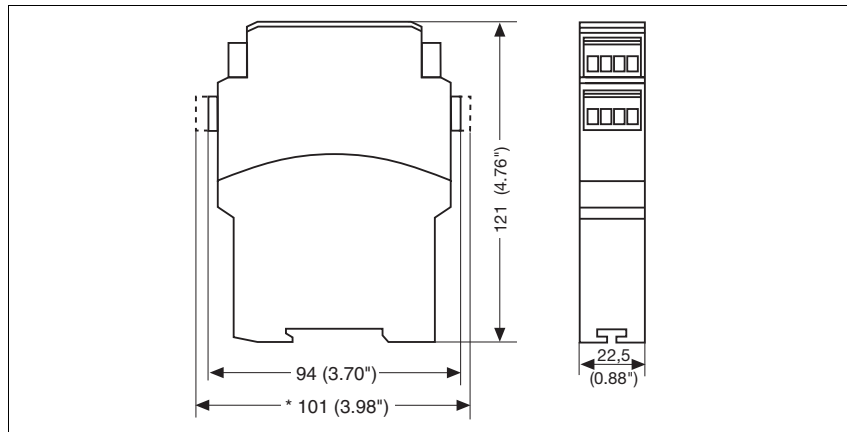

## Up to PL e of EN ISO 13849-1 PNOZ X1P

### Notice

This data sheet is only intended for use during configuration. For installation and operation, please refer to the operating instructions supplied with the unit.

### Service life graph

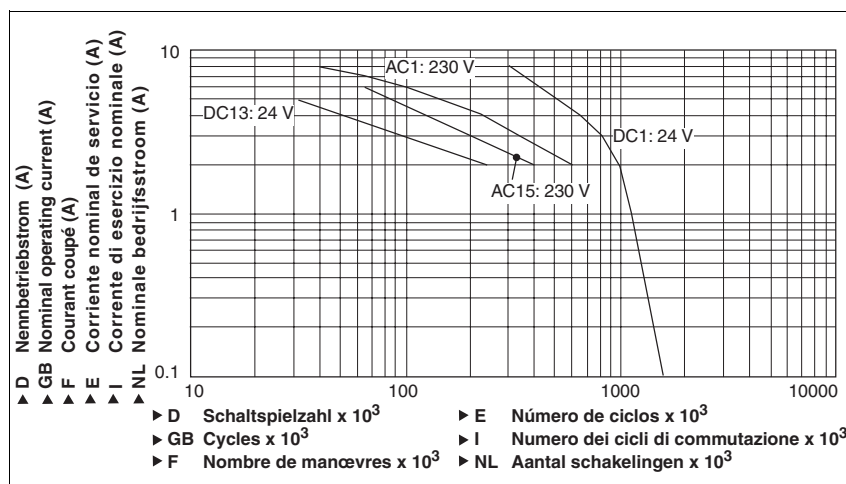

### Technical details

#### Electrical data

Supply voltage	
Supply voltage U <sub>B</sub> DC	<b>24 V</b>
Voltage tolerance	<b>-15 %/+10 %</b>
Power consumption at U <sub>B</sub> DC	<b>1.5 W</b>
Residual ripple DC	<b>160 %</b>
Voltage and current at	
Input circuit DC: <b>24.0 V</b>	<b>45.0 mA</b>
Reset circuit DC: <b>24.0 V</b>	<b>45.0 mA</b>
Feedback loop DC: <b>24.0 V</b>	<b>45.0 mA</b>
Number of output contacts	
Safety contacts (S) instantaneous:	<b>3</b>
Auxiliary contacts (N/C):	<b>1</b>
Utilisation category in accordance with <b>EN 60947-4-1</b>	
Safety contacts: AC1 at <b>240 V</b>	I <sub>min</sub> : <b>0.01 A</b> , I <sub>max</sub> : <b>6.0 A</b> P <sub>max</sub> : <b>1500 VA</b>
Safety contacts: DC1 at <b>24 V</b>	I <sub>min</sub> : <b>0.01 A</b> , I <sub>max</sub> : <b>6.0 A</b> P <sub>max</sub> : <b>150 W</b>
Auxiliary contacts: AC1 at <b>240 V</b>	I <sub>min</sub> : <b>0.01 A</b> , I <sub>max</sub> : <b>6.0 A</b> P <sub>max</sub> : <b>1500 VA</b>
Auxiliary contacts: DC1 at <b>24 V</b>	I <sub>min</sub> : <b>0.01 A</b> , I <sub>max</sub> : <b>6.0 A</b> P <sub>max</sub> : <b>150 W</b>
Utilisation category in accordance with <b>EN 60947-5-1</b>	
Safety contacts: AC15 at <b>230 V</b>	I <sub>max</sub> : <b>5.0 A</b>
Safety contacts: DC13 at <b>24 V</b> (6 cycles/min)	I <sub>max</sub> : <b>4.0 A</b>
Auxiliary contacts: AC15 at <b>230 V</b>	I <sub>max</sub> : <b>5.0 A</b>
Auxiliary contacts: DC13 at <b>24 V</b> (6 cycles/min)	I <sub>max</sub> : <b>4.0 A</b>
Contact material	<b>AgSnO2 + 0.2 µm Au</b>

## Up to PL e of EN ISO 13849-1 PNOZ X1P

<b>Electrical data</b>	
External contact fuse protection ( $I_k = 1 \text{ kA}$ ) to <b>EN 60947-5-1</b>	
Blow-out fuse, quick	
Safety contacts:	<b>6 A</b>
Auxiliary contacts:	<b>6 A</b>
Blow-out fuse, slow	
Safety contacts:	<b>4 A</b>
Auxiliary contacts:	<b>4 A</b>
Circuit breaker 24 VAC/DC, characteristic B/C	
Safety contacts:	<b>4 A</b>
Auxiliary contacts:	<b>4 A</b>
Max. overall cable resistance $R_{lmax}$ input circuits, reset circuits single-channel at $U_B$ DC	
	<b>30 Ohm</b>
<b>Safety-related characteristic data</b>	
PL in accordance with <b>EN ISO 13849-1</b>	<b>PL e (Cat. 4)</b>
Category in accordance with <b>EN 954-1</b>	<b>Cat. 4</b>
SIL CL in accordance with <b>EN IEC 62061</b>	<b>SIL CL 3</b>
PFH in accordance with <b>EN IEC 62061</b>	<b>2.31E-09</b>
SIL in accordance with <b>IEC 61511</b>	<b>SIL 3</b>
PFD in accordance with <b>IEC 61511</b>	<b>2.03E-06</b>
$t_M$ in years	<b>20</b>
<b>Times</b>	
Switch-on delay	
with automatic reset typ.	<b>60 ms</b>
with automatic reset max.	<b>120 ms</b>
with manual reset typ.	<b>50 ms</b>
with manual reset max.	<b>120 ms</b>
Delay-on de-energisation	
with E-STOP typ.	<b>55 ms</b>
with E-STOP max.	<b>90 ms</b>
with power failure typ.	<b>55 ms</b>
with power failure max.	<b>90 ms</b>
Recovery time at max. switching frequency 1/s	
after E-STOP	<b>150 ms</b>
after power failure	<b>150 ms</b>
Supply interruption before de-energisation	<b>20 ms</b>
<b>Environmental data</b>	
EMC	<b>EN 60947-5-1, EN 61000-6-2</b>
Vibration to <b>EN 60068-2-6</b>	
Frequency	<b>10 - 55 Hz</b>
Amplitude	<b>0.35 mm</b>
Climatic suitability	<b>EN 60068-2-78</b>
Airgap creepage in accordance with <b>EN 60947-1</b>	
Pollution degree	<b>2</b>
Overvoltage category	<b>III</b>
Rated insulation voltage	<b>250 V</b>
Rated impulse withstand voltage	<b>4.00 kV</b>
Ambient temperature	<b>-10 - 55 °C</b>
Storage temperature	<b>-40 - 85 °C</b>
Protection type	
Mounting (e.g. cabinet)	<b>IP54</b>
Housing	<b>IP40</b>
Terminals	<b>IP20</b>
<b>Mechanical data</b>	
Housing material	
Housing	<b>PPO UL 94 V0</b>
Front	<b>ABS UL 94 V0</b>

## Up to PL e of EN ISO 13849-1 PNOZ X1P

### Mechanical data

Cross section of external conductors with screw terminals	
1 core flexible	<b>0.25 - 2.50 mm<sup>2</sup> , 24 - 12 AWG</b> Order no.: 777100
2 core, same cross section, flexible:	
with crimp connectors, without insulating sleeve	<b>0.25 - 1.00 mm<sup>2</sup> , 24 - 16 AWG</b> Order no.: 777100
without crimp connectors or with TWIN crimp connectors	<b>0.20 - 1.50 mm<sup>2</sup> , 24 - 16 AWG</b> Order no.: 777100
Torque setting with screw terminals	<b>0.50 Nm</b> Order no.: 777100
Cross section of external conductors with spring-loaded terminals: Flexible with/without crimp connectors	
Spring-loaded terminals: Terminal points per connection	<b>2</b> Order no.: 787100
Stripping length	<b>8 mm</b> Order no.: 787100
Dimensions	
Height	<b>101.0 mm</b> Order no.: 787100 <b>94.0 mm</b> Order no.: 777100
Width	<b>22.5 mm</b>
Depth	<b>121.0 mm</b>
Weight	<b>200 g</b> Order no.: 787100 <b>205 g</b> Order no.: 777100

The standards current on **2004-09** apply.

### Conventional thermal current

$I_{th}$  (A) at  $U_B$  DC

1 contact	<b>6.00 A</b>
2 contacts	<b>6.00 A</b>
3 contacts	<b>4.50 A</b>

### Order reference

Type	Features	Terminals	Order no.
PNOZ X1P C	24 VDC	Spring-loaded terminals	787 100
PNOZ X1P	24 VDC	Screw terminals	777 100