

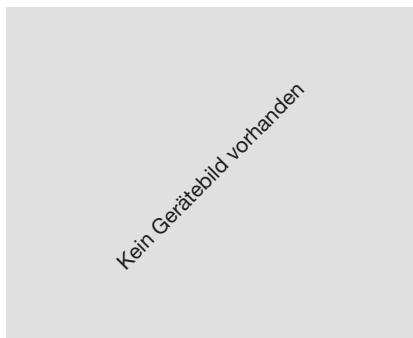



Up to Category 2, EN 954-1 PNOZ X7.1



Safety relay for monitoring E-STOP pushbuttons.

Approvals

	PNOZ X7.1
	◆
	◆
	◆

Unit features

- ▶ Positive-guided relay outputs:
 - 1 safety contact (N/O), instantaneous
 - 1 auxiliary contact (N/C), instantaneous
- ▶ Connection options for:
 - E-STOP pushbutton
 - Safety gate limit switch
 - Reset button
- ▶ LED indicator for:
 - Switch status channel 1/2
 - Supply voltage

Unit description

The safety relay meets the requirements of EN 60204-1 and IEC 60204-1 and may be used in applications with

- ▶ E-STOP pushbuttons

The safety relay is not suitable for non-contact barriers because

- ▶ a dynamic start is not possible
- ▶ the unit can be started during the delay-on de-energisation time.

Safety features

The relay meets the following safety requirements:

- ▶ The circuit is redundant with built-in self-monitoring.
- ▶ The safety function remains effective in the case of a component failure.
- ▶ The correct opening and closing of the safety function relays is tested automatically in each on-off cycle.

Block diagram

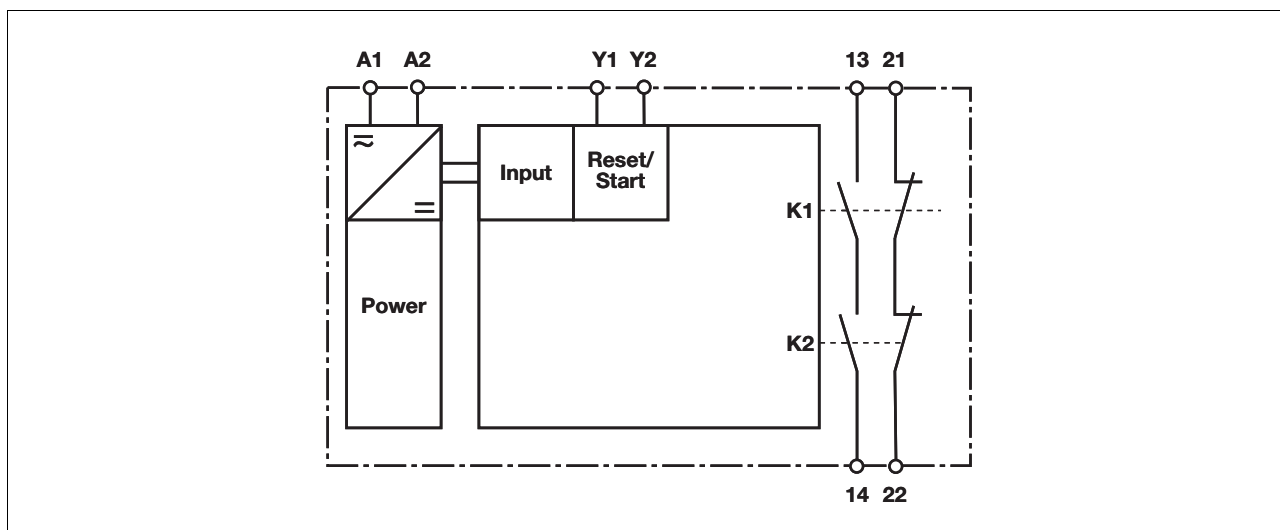

Up to Category 2, EN 954-1 PNOZ X7.1

Function description

- ▶ Single-channel operation: no redundancy in the input circuit, earth faults in the reset and input circuit are detected.
- ▶ Automatic start: Unit is active once the input circuit has been closed.
- ▶ Manual reset: Unit is active once the input circuit is closed and then the reset circuit is closed.
- ▶ Increase in the number of available contacts by connecting contact expander modules or external contactors/relays.

Timing diagram

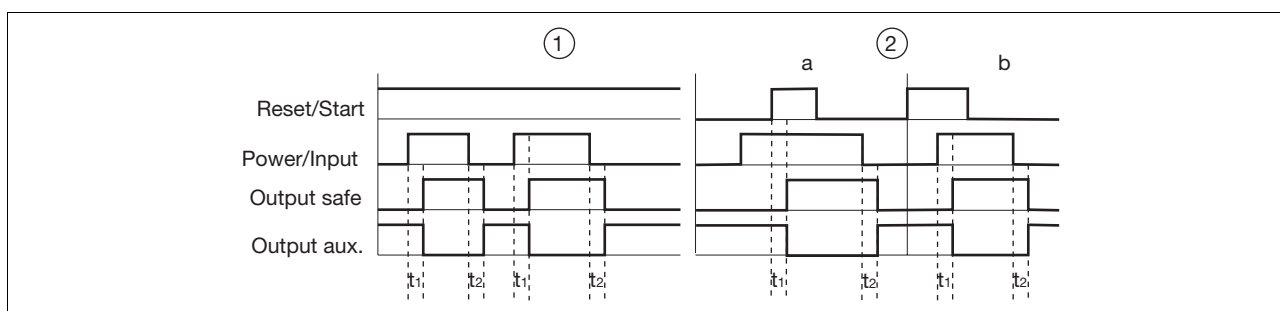

Key

- ▶ Power: Supply voltage
- ▶ Reset/start: Reset circuit Y1-Y2
- ▶ Input: Input circuits A1
- ▶ Output safe: Safety contacts 13-14
- ▶ Output aux: Auxiliary contacts 21-22
- ▶ ①: Automatic reset
- ▶ ②: Manual reset
- ▶ a: Input circuit closes before reset circuit
- ▶ b: Reset circuit closes before input circuit
- ▶ t_1 : Switch-on delay
- ▶ t_2 : Delay-on de-energisation

Wiring

Please note:

- ▶ Information given in the “Technical details” must be followed.
- ▶ Outputs 13-14 are safety contacts, output 21-22 is an auxiliary contact (e.g. for display).
- ▶ To prevent contact welding, a fuse should be connected before the output contacts (see technical details).
- ▶ Calculation of the max. cable runs l_{max} in the input circuit:

$$l_{max} = \frac{R_{lmax}}{R_l / km}$$

R_{lmax} = max. overall cable resistance (see technical details)

R_l / km = cable resistance/km

- ▶ Use copper wire that can withstand 60/75 °C.
- ▶ Sufficient fuse protection must be provided on all output contacts with capacitive and inductive loads.

Up to Category 2, EN 954-1 PNOZ X7.1

Preparing for operation

▶ Supply voltage

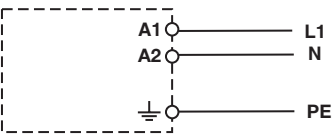
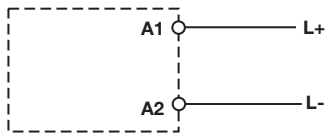
Supply voltage	AC	DC
		

▶ Input circuit

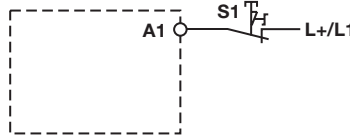
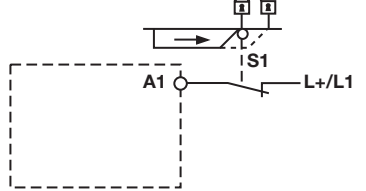
Input circuit	Single-channel	Dual-channel
E-STOP without detection of shorts across contacts		

▶ Reset circuit

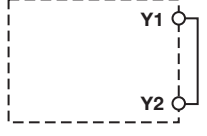
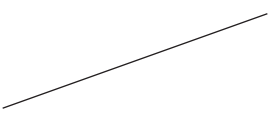
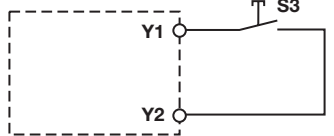
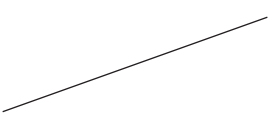

Reset circuit	E-STOP wiring (single-channel)	E-STOP wiring (dual-channel)
Automatic reset		
Manual reset		

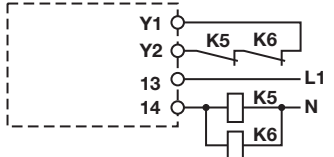
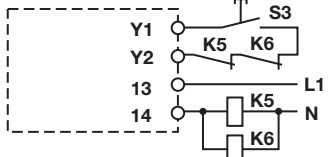
▶ Feedback loop

Feedback loop	Automatic reset	Manual reset
Contacts from external contactors		

Up to Category 2, EN 954-1 PNOZ X7.1

▶ Key

S1/S2	Two-hand button
S3	Reset button
	Switch operated
	Gate open
	Gate closed

Terminal configuration

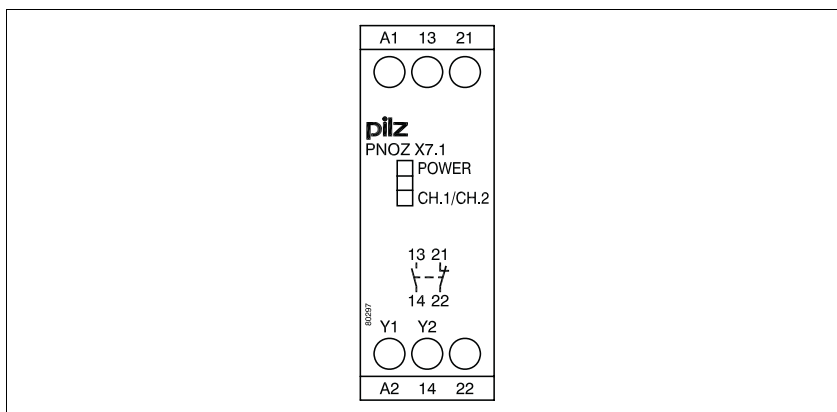

Installation

- ▶ The safety relay should be installed in a control cabinet with a protection type of at least IP54.
- ▶ Use the notch on the rear of the unit to attach it to a DIN rail.
- ▶ Ensure the unit is mounted securely on a vertical DIN rail (35 mm) by using a fixing element (e.g. retaining bracket or an end angle).

Dimensions

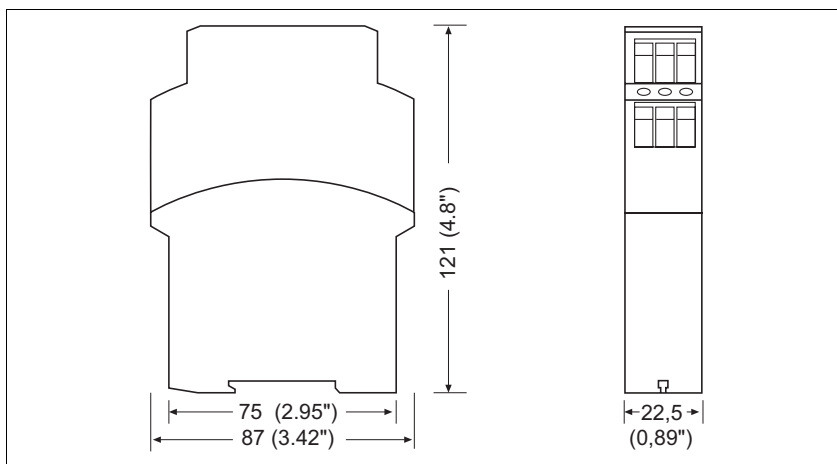

Up to Category 2, EN 954-1 PNOZ X7.1

Notice

This data sheet is only intended for use during configuration. For installation and operation, please refer to the operating instructions supplied with the unit.

Service life graph

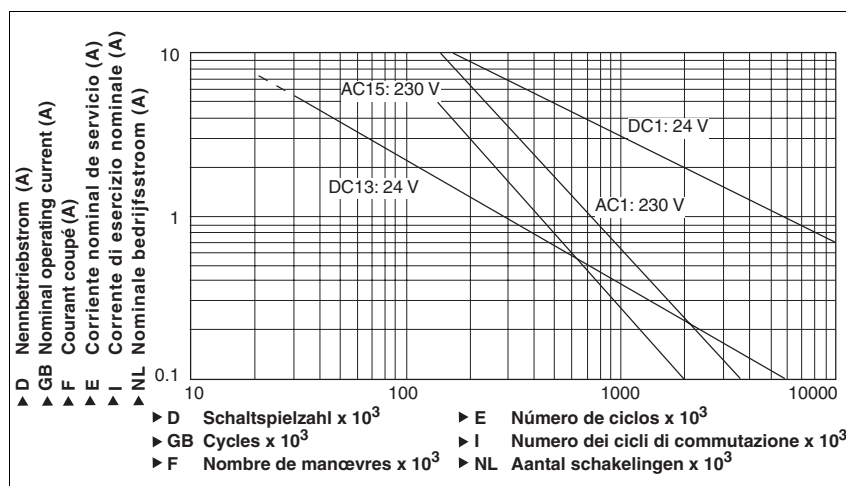

Technical details

Electrical data

Supply voltage U_B	24 VAC/DC
Voltage tolerance	-15% / +10%
Power consumption at U_B AC	3.0 VA
Power consumption at U_B DC	1.5 W
Frequency range AC	50 - 60 Hz
Residual ripple DC	160 %
Voltage and current at input circuit: 24 VDC	50 mA
reset circuit: 24 VDC	210 mA
feedback loop: 24 VDC	210 mA
Output contacts in accordance with EN 954-1 , Category 2	Safety contacts (N/O): 1 Auxiliary contacts (N/C): 1
Utilisation category in accordance with EN 60947-4-1 AC1: 240 V	I_{min} : 0.01 A I_{max} : 6.00 A P_{max} : 1,500 VA
DC1: 24 V	I_{min} : 0.01 A I_{max} : 6.0 A P_{max} : 150
Utilisation category in accordance with EN 60947-5-1 AC15: 230 V DC13 (6 cycles/min): 24 V	I_{max} : 5.0 A I_{max} : 6.0 A
Contact material	AgSnO₂ + 0.2 μm Au
External contact fuse protection (EN 60947-5-1)	
Blow-out fuse, quick	6 A
Blow-out fuse, slow	4 A
Circuit breaker	4 A, 24 VAC/DC, characteristic B/C
Max. overall cable resistance R_{lmax} input circuits, reset circuits	
Single-channel at U_B DC	15 Ohm
Single-channel at U_B AC	15 Ohm

Up to Category 2, EN 954-1 PNOZ X7.1

Times	
Switch-on delay	
with automatic reset typ.	50 ms
with automatic reset max.	150 ms
with automatic reset after power on typ.	50 ms
with automatic reset after power on max.	150 ms
with manual reset typ.	35 ms
with manual reset max.	150 ms
Delay-on de-energisation	
with E-STOP typ.	45 ms
with E-STOP max.	70 ms
with power failure typ.	45 ms
with power failure max.	70 ms
Recovery time at max. switching frequency 1/s after E-STOP	50 ms
after power failure	150 ms
Supply interruption before de-energisation	20 ms
Environmental data	
EMC	EN 60947-5-1, EN 61000-6-2
Vibration in accordance with EN 60068-2-6	
Frequency	10 - 55 Hz
Amplitude	0.35 mm
Climatic suitability	EN 60068-2-78
Airgap creepage	EN 60947-1
Ambient temperature	-10 - 55 °C
Storage temperature	-40 - 85 °C
Protection type	
Mounting (e.g. cabinet)	IP54
Housing	IP40
Terminals	IP20
Mechanical data	
Housing material	
Housing	PPO UL 94 V0
Front	ABS UL 94 V0
Max. cross section of external conductors with screw terminals	
1 core flexible	0.20 - 4.00 mm ²
2 core, same cross section, flexible:	
with crimp connectors, without insulating sleeve	0.20 - 2.50 mm ²
without crimp connectors or with TWIN crimp connectors	0.20 - 2.50 mm ²
Torque setting with screw terminals	0.60 Nm
Dimensions (H x W x D)	87.0 mm x 22.5 mm x 121.0 mm
Weight	190 g

The standards current on 09/04 apply.

Order reference			
Type	Features	Terminals	Order no.
PNOZ X7.1	24 VAC/DC	Screw terminals	774 051