

## Up to PL e of EN ISO 13849-1 PNOZ X9



Safety relay for monitoring E-STOP pushbuttons, safety gates and light barriers.

### Approvals

PNOZ X9	
	◆
	◆
	◆

### Unit features

- ▶ Positive-guided relay outputs:
  - 7 safety contacts (N/O), instantaneous
  - 2 auxiliary contacts (N/C), instantaneous
- ▶ 2 semiconductor outputs
- ▶ Connection options for:
  - E-STOP pushbutton
  - Safety gate limit switch
  - Reset button
  - Light barriers
- ▶ LED indicator for:
  - Switch status channel 1/2
  - Supply voltage
  - Reset circuit
  - Input circuits
- ▶ Semiconductor output signals:
  - Supply voltage is present
  - Switch status channel 1/2
- ▶ See order reference for unit types

- ▶ Safety gates
- ▶ Light barriers

### Safety features

The relay meets the following safety requirements:

- ▶ The circuit is redundant with built-in self-monitoring.
- ▶ The safety function remains effective in the case of a component failure.
- ▶ The correct opening and closing of the safety function relays is tested automatically in each on-off cycle.
- ▶ The transformer is short circuit-proof. An electronic fuse is used on a DC supply.

### Unit description

The safety relay meets the requirements of EN 60947-5-1, EN 60204-1 and VDE 0113-1 and may be used in applications with

- ▶ E-STOP pushbuttons

### Block diagram

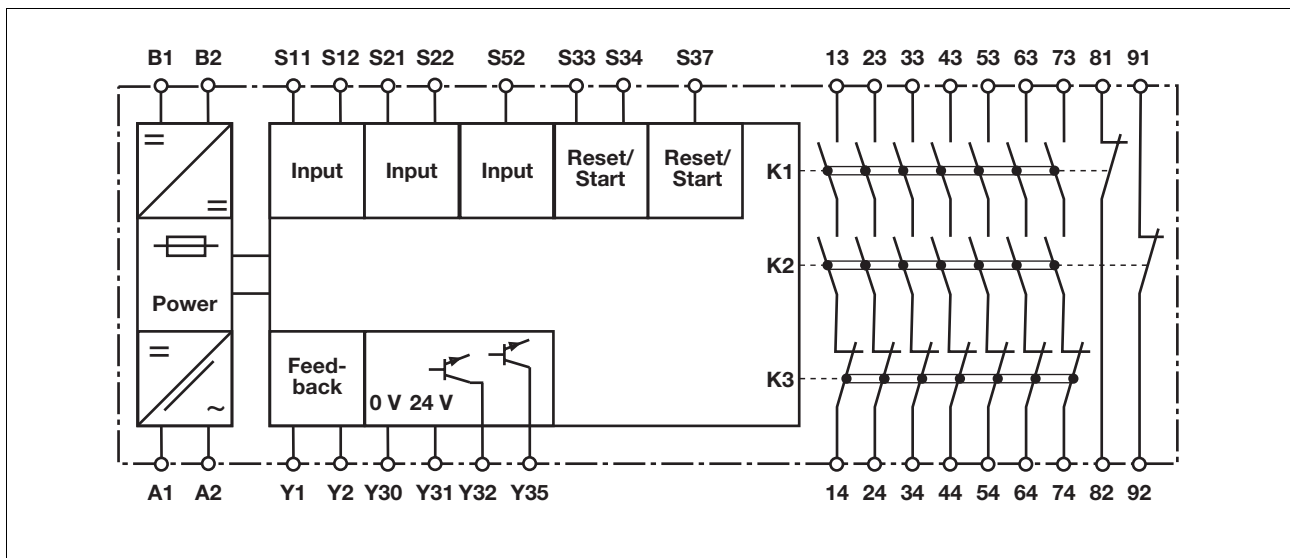

## Up to PL e of EN ISO 13849-1 PNOZ X9

### Function description

- ▶ Single-channel operation: no redundancy in the input circuit, earth faults in the reset and input circuit are detected.
- ▶ Dual-channel operation without detection of shorts across contacts: redundant input circuit, detects
  - earth faults in the reset and input circuit,
  - short circuits in the input circuit and, with a monitored reset, in the reset circuit too.
- ▶ Dual-channel operation with detection of shorts across contacts: redundant input circuit, detects
  - earth faults in the reset and input circuit,
  - short circuits in the input circuit and, with a monitored reset, in the reset circuit too,
  - shorts between contacts in the input circuit.
- ▶ Automatic start: Unit is active once the input circuit has been closed.
- ▶ Manual reset: Unit is active once the input circuit is closed and then the reset circuit is closed.
- ▶ Monitored reset: Unit is active once
  - the input circuit is closed and then the reset circuit is closed and opened again.
  - the reset circuit is closed and then opened again once the input circuit is closed.
- ▶ Increase in the number of available contacts by connecting contact expansion modules or external contactors/relays.

### Timing diagram

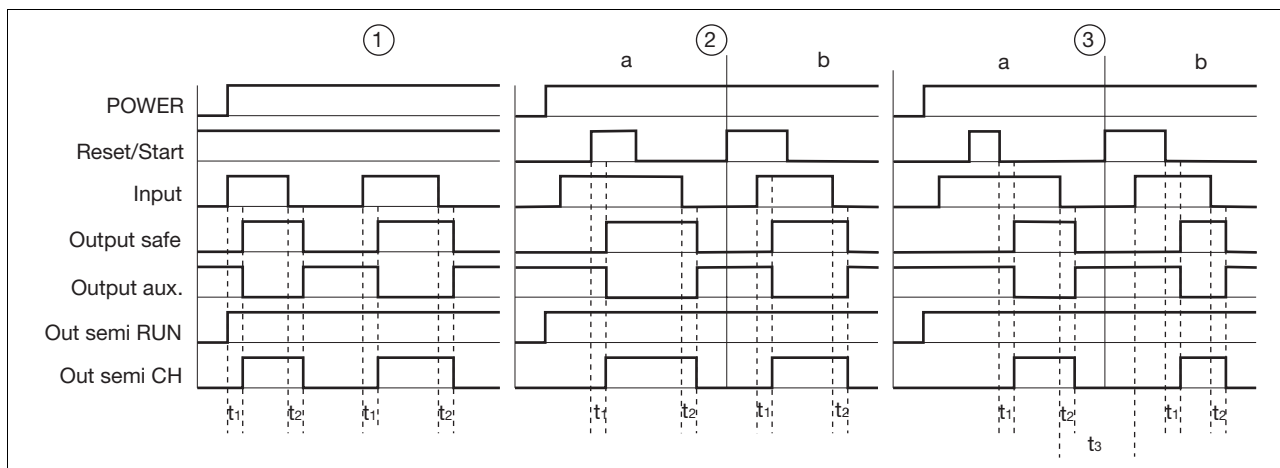

### Key

- ▶ Power: Supply voltage
- ▶ Reset/start: Reset circuit S33-S34
- ▶ Input: Input circuits S11-S12, S21-S22, S52
- ▶ Output safe: Safety contacts 13-14, 23-24, 33-34, 43-44, 53-54, 63-64, 73-74
- ▶ Output aux.: Auxiliary contacts 81-82, 91-92
- ▶ Out semi RUN: Semiconductor output supply voltage Y35
- ▶ Out semi CH: Semiconductor output switch status Y32
- ▶ ①: Automatic reset
- ▶ ②: Manual reset
- ▶ ③: Monitored reset
- ▶ a: Input circuit closes before reset circuit
- ▶ b: Reset circuit closes before input circuit
- ▶ t<sub>1</sub>: Switch-on delay
- ▶ t<sub>2</sub>: Delay-on de-energisation
- ▶ t<sub>3</sub>: Recovery time

### Wiring

#### Please note:

- ▶ Information given in the “Technical details” must be followed.
- ▶ Outputs 13-14, 23-24, 33-34, 43-44, 53-54, 63-64, 73-74 are safety contacts, outputs 81-82, 91-92 are auxiliary contacts (e.g. for display).
- ▶ To prevent contact welding, a fuse should be connected before the output contacts (see technical details).
- ▶ Calculation of the max. cabling runs  $I_{max}$  in the input circuit:
 
$$I_{max} = \frac{R_{lmax}}{R_l / km}$$

$R_{lmax}$  = max. overall cable resistance (see technical details)  
 $R_l / km$  = cable resistance/km
- ▶ Use copper wire that can withstand 60/75 °C.
- ▶ Sufficient fuse protection must be provided on all output contacts with capacitive and inductive loads.

## Up to PL e of EN ISO 13849-1 PNOZ X9

### Preparing for operation

#### ► Supply voltage

Supply voltage	AC	DC

#### ► Input circuit

Input circuit	Single-channel	Dual-channel
E-STOP <b>without</b> detection of shorts across contacts		
E-STOP <b>with</b> detection of shorts across contacts		
Safety gate <b>without</b> detection of shorts across contacts		
Safety gate <b>with</b> detection of shorts across contacts		
Light barrier <b>with</b> detection of shorts across contacts via ESPE		

## Up to PL e of EN ISO 13849-1 PNOZ X9

### ▶ Reset circuit

Reset circuit	E-STOP/safety gate wiring (single and dual-channel, without shorts across contacts)	E-STOP/safety gate wiring (dual-channel, with shorts across contacts)
Automatic reset		
Manual reset		
Monitored reset		

### ▶ Feedback loop

Feedback loop	
Contacts from external contactors	

### ▶ Semiconductor output

--

### ▶ Key

S1/S2	E-STOP/safety gate switch
S3	Reset button
	Switch operated
	Gate open
	Gate closed

## Up to PL e of EN ISO 13849-1 PNOZ X9

### Terminal configuration

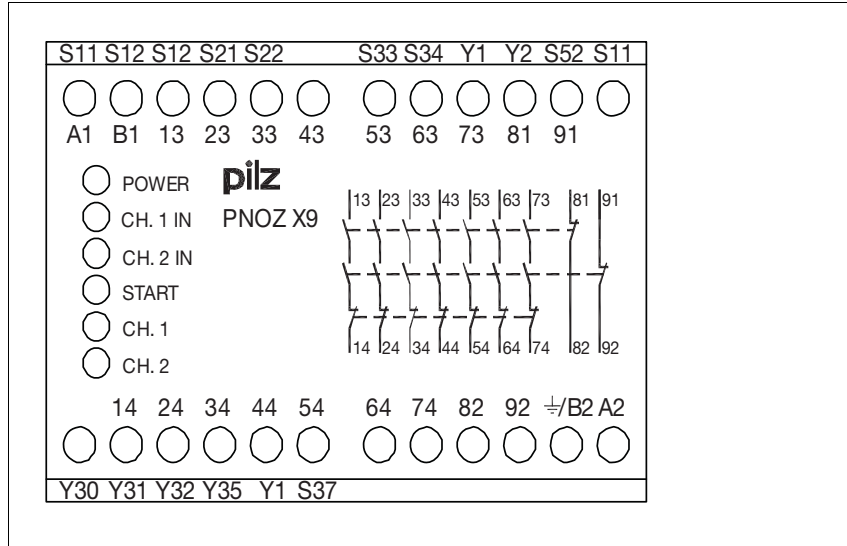

### Installation

- ▶ The safety relay should be installed in a control cabinet with a protection type of at least IP54.
- ▶ Use the notch on the rear of the unit to attach it to a DIN rail.
- ▶ Ensure the unit is mounted securely on a vertical DIN rail (35 mm) by using a fixing element (e.g. retaining bracket or an end angle).

### Dimensions

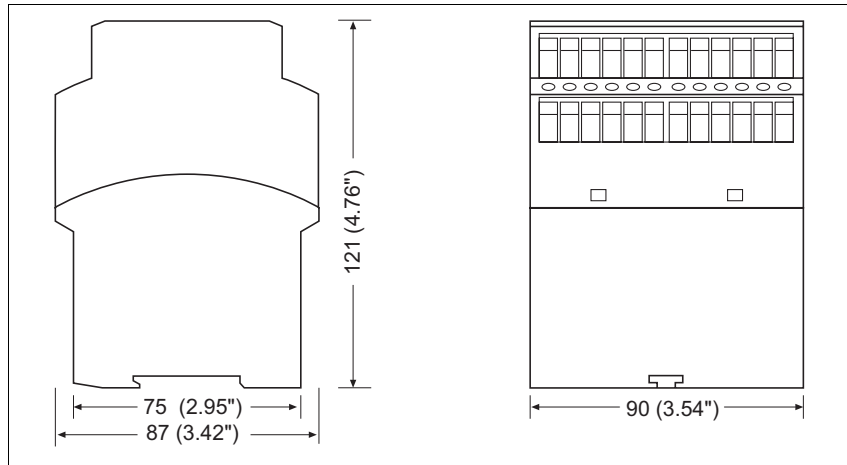

## Up to PL e of EN ISO 13849-1 PNOZ X9

### Notice

This data sheet is only intended for use during configuration. For installation and operation, please refer to the operating instructions supplied with the unit.

### Service life graph

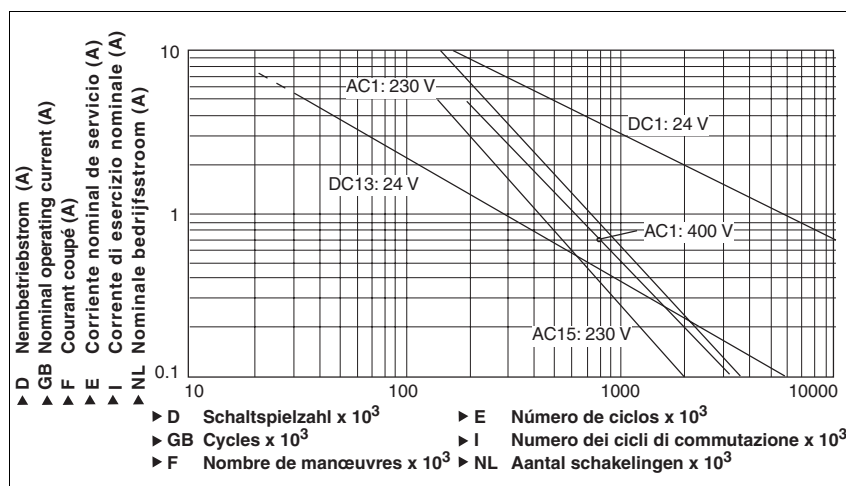

### Technical details

#### Electrical data

Supply voltage	
Supply voltage $U_B$ AC	<b>24 V, 42 V, 100 - 120 V, 200 - 230 V</b>
Supply voltage $U_B$ DC	<b>24 V</b>
Voltage tolerance	<b>-15 %/+10 %</b>
Power consumption at $U_B$ AC	<b>11.0 VA</b>
Power consumption at $U_B$ DC	<b>5.5 W</b>
Frequency range AC	<b>50 - 60 Hz</b>
Residual ripple DC	<b>160 %</b>
Voltage and current at	
Input circuit DC: <b>24.0 V</b>	<b>50.0 mA</b>
Reset circuit DC: <b>24.0 V</b>	<b>100.0 mA</b>
Feedback loop DC: <b>24.0 V</b>	<b>100.0 mA</b>
Number of output contacts	
Safety contacts (S) instantaneous:	<b>7</b>
Auxiliary contacts (N/C):	<b>2</b>
Utilisation category in accordance with <b>EN 60947-4-1</b>	
Safety contacts: AC1 at <b>240 V</b>	$I_{min}$ : <b>0.01 A</b> , $I_{max}$ : <b>8.0 A</b> $P_{max}$ : <b>2000 VA</b>
Safety contacts: AC1 at <b>400 V</b>	$I_{min}$ : <b>0.01 A</b> , $I_{max}$ : <b>5.00 A</b> $P_{max}$ : <b>2000 VA</b>
Safety contacts: DC1 at <b>24 V</b>	$I_{min}$ : <b>0.01 A</b> , $I_{max}$ : <b>8.0 A</b> $P_{max}$ : <b>200 W</b>
Auxiliary contacts: AC1 at <b>240 V</b>	$I_{min}$ : <b>0.01 A</b> , $I_{max}$ : <b>8.0 A</b> $P_{max}$ : <b>2000 VA</b>
Auxiliary contacts: DC1 at <b>24 V</b>	$I_{min}$ : <b>0.01 A</b> , $I_{max}$ : <b>8.0 A</b> $P_{max}$ : <b>200 W</b>
Utilisation category in accordance with <b>EN 60947-5-1</b>	
Safety contacts: AC15 at <b>230 V</b>	$I_{max}$ : <b>5.0 A</b>
Safety contacts: DC13 at <b>24 V</b> (6 cycles/min)	$I_{max}$ : <b>7.0 A</b>
Auxiliary contacts: AC15 at <b>230 V</b>	$I_{max}$ : <b>5.0 A</b>
Auxiliary contacts: DC13 at <b>24 V</b> (6 cycles/min)	$I_{max}$ : <b>7.0 A</b>
Contact material	<b>AgSnO<sub>2</sub> + 0.2 µm Au</b>

## Up to PL e of EN ISO 13849-1 PNOZ X9

<b>Electrical data</b>	
External contact fuse protection ( $I_k = 1 \text{ kA}$ ) to <b>EN 60947-5-1</b>	
Blow-out fuse, quick	
Safety contacts:	<b>10 A</b>
Auxiliary contacts:	<b>10 A</b>
Blow-out fuse, slow	
Safety contacts:	<b>6 A</b>
Auxiliary contacts:	<b>6 A</b>
Circuit breaker 24 VAC/DC, characteristic B/C	
Safety contacts:	<b>6 A</b>
Auxiliary contacts:	<b>6 A</b>
Semiconductor outputs (short circuit proof)	<b>24.0 V DC, 20 mA</b>
External supply voltage	<b>24.0 V DC</b>
Voltage tolerance	<b>-20 %/+20 %</b>
Max. overall cable resistance $R_{lmax}$ input circuits, reset circuits	
single-channel at $U_B$ DC	<b>45 Ohm</b>
single-channel at $U_B$ AC	<b>45 Ohm</b>
dual-channel without detect. of shorts across contacts at $U_B$ DC	<b>90 Ohm</b>
dual-channel without detect. of shorts across contacts at $U_B$ AC	<b>90 Ohm</b>
dual-channel with detect. of shorts across contacts at $U_B$ DC	<b>15 Ohm</b>
dual-channel with detect. of shorts across contacts at $U_B$ AC	<b>15 Ohm</b>
<b>Safety-related characteristic data</b>	
PL in accordance with <b>EN ISO 13849-1</b>	<b>PL e (Cat. 4)</b>
Category in accordance with <b>EN 954-1</b>	<b>Cat. 4</b>
SIL CL in accordance with <b>EN IEC 62061</b>	<b>SIL CL 3</b>
PFH in accordance with <b>EN IEC 62061</b>	<b>2.31E-09</b>
SIL in accordance with <b>IEC 61511</b>	<b>SIL 3</b>
PFD in accordance with <b>IEC 61511</b>	<b>2.03E-06</b>
$t_M$ in years	<b>20</b>
<b>Times</b>	
Switch-on delay	
with automatic reset typ.	<b>200 ms</b>
with automatic reset max.	<b>250 ms</b>
with automatic reset after power on typ.	<b>220 ms</b>
with automatic reset after power on max.	<b>300 ms</b>
with manual reset typ.	<b>200 ms</b>
with manual reset max.	<b>250 ms</b>
on monitored reset with rising edge typ.	<b>150 ms</b>
on monitored reset with rising edge max.	<b>220 ms</b>
Delay-on de-energisation	
with E-STOP typ.	<b>20 ms</b>
with E-STOP max.	<b>30 ms</b>
with power failure typ.	<b>170 ms</b>
with power failure max.	<b>250 ms</b>
Recovery time at max. switching frequency 1/s	
after E-STOP	<b>50 ms</b>
after power failure	<b>300 ms</b>
Min. start pulse duration with a monitored reset	
with rising edge	<b>50 ms</b>
Simultaneity, channel 1 and 2	<b>150 ms</b>
Supply interruption before de-energisation	<b>35 ms</b>
<b>Environmental data</b>	
EMC	<b>EN 60947-5-1, EN 61000-6-2</b>
Vibration to <b>EN 60068-2-6</b>	
Frequency	<b>10 - 55 Hz</b>
Amplitude	<b>0.35 mm</b>
Climatic suitability	<b>EN 60068-2-78</b>

## Up to PL e of EN ISO 13849-1 PNOZ X9

Environmental data	
Airgap creepage in accordance with EN 60947-1	
Pollution degree	2
Overvoltage category	III
Rated insulation voltage	250 V
Rated impulse withstand voltage	4.0 kV
Ambient temperature	-10 - 55 °C
Storage temperature	-40 - 85 °C
Protection type	
Mounting (e.g. cabinet)	IP54
Housing	IP40
Terminals	IP20
Mechanical data	
Housing material	
Housing	PPO UL 94 V0
Front	ABS UL 94 V0
Cross section of external conductors with screw terminals	
1 core flexible	0.20 - 4.00 mm <sup>2</sup> , 24 - 10 AWG
2 core, same cross section, flexible:	
with crimp connectors, without insulating sleeve	0.20 - 2.50 mm <sup>2</sup> , 24 - 14 AWG
without crimp connectors or with TWIN crimp connectors	0.20 - 2.50 mm <sup>2</sup> , 24 - 14 AWG
Torque setting with screw terminals	0.60 Nm
Dimensions	
Height	87.0 mm
Width	90.0 mm
Depth	121.0 mm
Weight	750 g

The standards current on **06/04** apply.

Conventional thermal current		
Number of contacts	$I_{th}$ (A) at $U_B$ DC	$I_{th}$ (A) at $U_B$ AC
1	8.00 A	8.00 A
2	8.00 A	5.60 A
3	8.00 A	4.60 A
4	7.00 A	4.00 A
5	6.00 A	3.50 A
6	5.50 A	3.20 A
7	5.00 A	3.00 A

Order reference			
Type	Features	Terminals	Order no.
PNOZ X9	24 VAC/DC	Screw terminals	774 609
PNOZ X9	42 VAC                      24 VDC	Screw terminals	774 601
PNOZ X9	110 - 120 VAC                      24 VDC	Screw terminals	774 605
PNOZ X9	220 - 230 VAC                      24 VDC	Screw terminals	774 606