

Up to PL e of EN ISO 13849-1 PNOZ XV1P



Safety relay for monitoring E-STOP pushbuttons and safety gates.

Approvals

	PNOZ XV1P
	◆
	◆
	◆

Unit features

- ▶ Positive-guided relay outputs:
 - 2 safety contacts (N/O), instantaneous
 - 1 safety contact (N/O), delay-on de-energisation
- ▶ Connection options for:
 - E-STOP pushbutton
 - Safety gate limit switch
 - Reset button
 - Light barriers
- ▶ LED indicator for:
 - Switch status channel 1/2
 - Supply voltage
- ▶ Plug-in connection terminals (either spring-loaded terminal or screw terminal)
- ▶ See order reference for unit types

- ▶ Safety gates
- ▶ Light beam devices

Safety features

- The relay meets the following safety requirements:
- ▶ The circuit is redundant with built-in self-monitoring.
 - ▶ The safety function remains effective in the case of a component failure.
 - ▶ The correct opening and closing of the safety function relays is tested automatically in each on-off cycle.
 - ▶ The unit has an electronic fuse.

Unit description

The max. category the safety contacts can achieve in accordance with EN 954-1 and EN ISO 13849-1 is stated in the technical details.

The safety relay meets the requirements of EN 60947-5-1, EN 60204-1 and VDE 0113-1 and may be used in applications with

- ▶ E-STOP pushbuttons

Block diagram

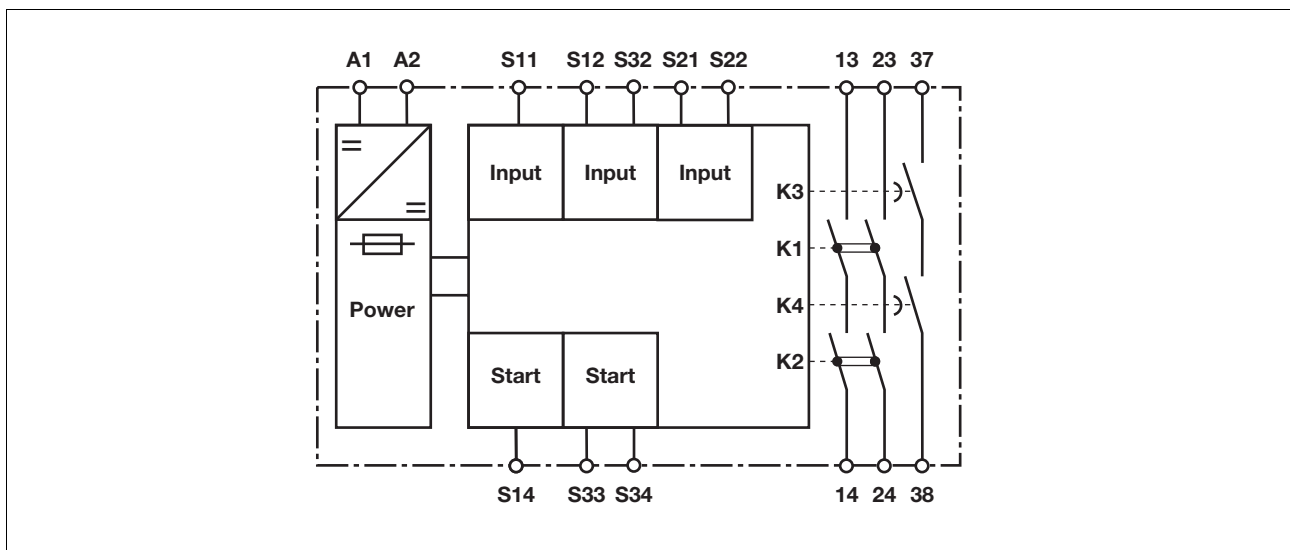

Up to PL e of EN ISO 13849-1 PNOZ XV1P

Function description

- ▶ Single-channel operation: no redundancy in the input circuit, earth faults in the reset and input circuit are detected.
- ▶ Dual-channel operation with detection of shorts across contacts: redundant input circuit, detects
 - earth faults in the reset and input circuit,
 - short circuits in the input circuit
- ▶ Dual-channel operation without detection of shorts across contacts: redundant input circuit, detects
 - earth faults in the reset and input circuit,
 - short circuits in the input circuit and, with a monitored reset, in the reset circuit too,
- ▶ Automatic start: Unit is active once the input circuit has been closed.
- ▶ Monitored reset: Unit is active once the input circuit is closed and once the reset circuit is closed after the waiting period has elapsed (see technical details).
- ▶ Increase in the number of available instantaneous safety contacts by connecting contact expansion modules or external contactors.

Timing diagram

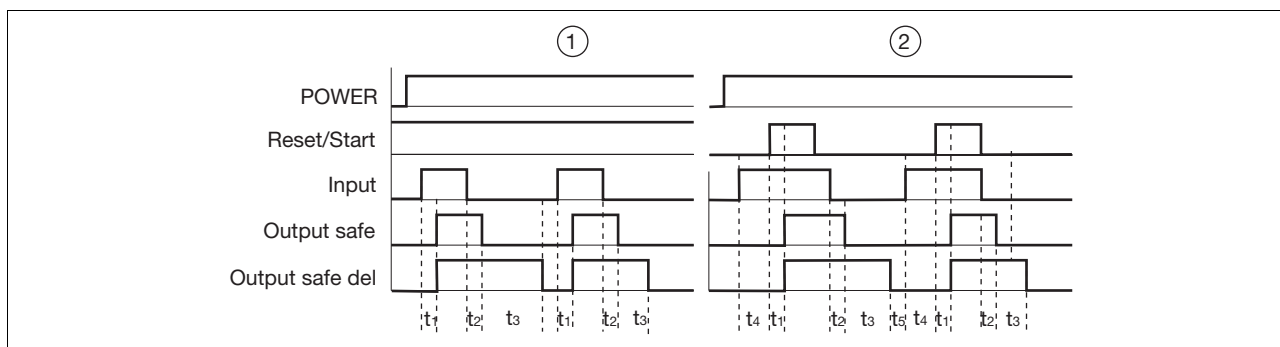

Key

- ▶ Power: Supply voltage
- ▶ Reset/Start: Reset circuit S11-S14, S33-S34
- ▶ Input: Input circuits S11-S12, S12-S32, S21-S22
- ▶ Output safe: Safety contacts, instantaneous 13-14, 23-24
- ▶ Output safe del: Safety contacts, delayed 37-38
- ▶ ①: Automatic reset
- ▶ ②: Monitored reset
- ▶ t₁: Switch-on delay
- ▶ t₂: Delay-on de-energisation
- ▶ t₃: Delay time
- ▶ t₄: Waiting period
- ▶ t₅: Recovery time

Wiring

Please note:

- ▶ Information given in the “Technical details” must be followed.
- ▶ Outputs 37-38 are delay-on de-energisation safety contacts.
- ▶ To prevent contact welding, a fuse should be connected before the output contacts (see technical details).
- ▶ Calculation of the max. cable runs I_{max} in the input circuit:

$$I_{\max} = \frac{R_{I_{\max}}}{R_l / \text{km}}$$

R_{I_{max}} = max. overall cable resistance (see technical details)

R_l /km = cable resistance/km

- ▶ Use copper wire that can withstand 60/75 °C.

- ▶ Sufficient fuse protection must be provided on all output contacts with capacitive and inductive loads.

Up to PL e of EN ISO 13849-1 PNOZ XV1P

Preparing for operation

► Supply voltage

Supply voltage	AC	DC

► Input circuit

Input circuit	Single-channel	Dual-channel
E-STOP without detection of shorts across contacts		
E-STOP with detection of shorts across contacts		
Safety gate without detection of shorts across contacts		
Safety gate with detection of shorts across contacts		
Light beam device with detection of shorts across contacts via ESPE		

Up to PL e of EN ISO 13849-1 PNOZ XV1P

▶ Reset circuit

Reset circuit	E-STOP wiring, safety gate	Safety gate (dual-channel)
Automatic reset		
Monitored reset		

▶ Feedback circuit

Feedback circuit	Automatic reset	Monitored reset
Contacts from external contactors		

▶ Key

S1/S2	E-STOP/safety gate switch
S3	Reset button
	Switch operated
	Gate open
	Gate closed

Up to PL e of EN ISO 13849-1 PNOZ XV1P

Terminal configuration

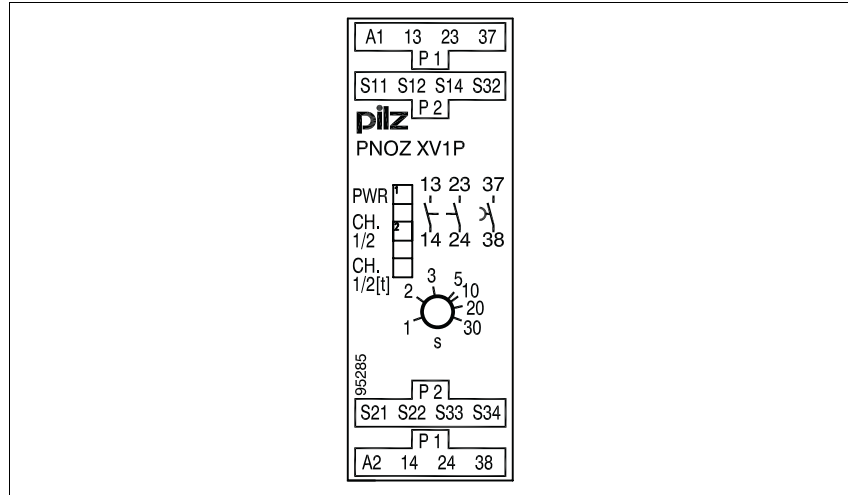

Installation

- ▶ The safety relay should be installed in a control cabinet with a protection type of at least IP54.
- ▶ Use the notch on the rear of the unit to attach it to a DIN rail.
- ▶ Ensure the unit is mounted securely on a vertical DIN rail (35 mm) by using a fixing element (e.g. retaining bracket or an end angle).

Dimensions

* with spring-loaded terminals

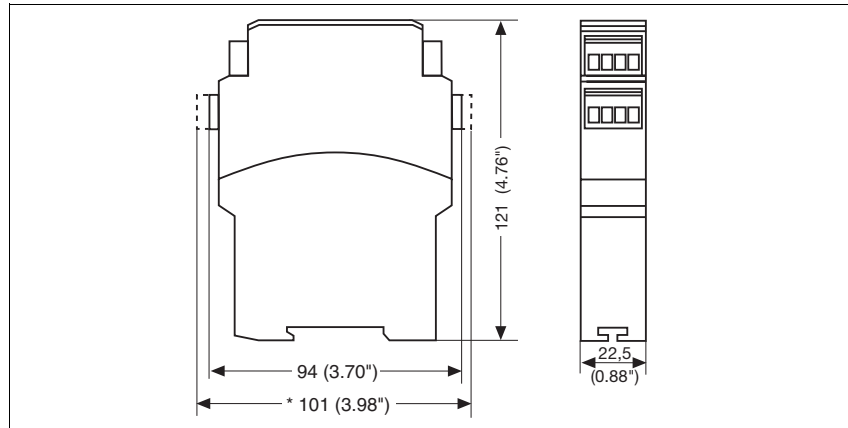

Up to PL e of EN ISO 13849-1 PNOZ XV1P

Notice

This data sheet is only intended for use during configuration. For installation and operation, please refer to the operating instructions supplied with the unit.

Service life graph

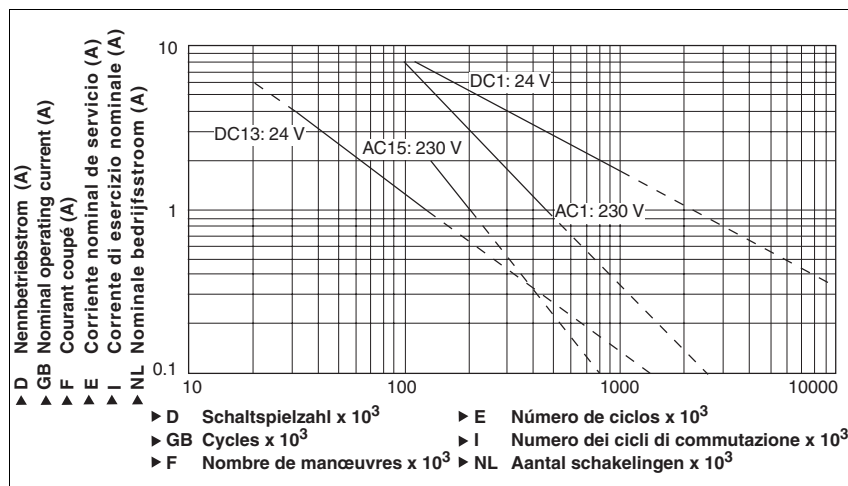

Technical details

Electrical data

Supply voltage	
Supply voltage U_B DC	24 V
Voltage tolerance	-15 %/+10 %
Power consumption at U_B DC	3.5 W
Residual ripple DC	20 %
Voltage and current at	
Input circuit DC: 24.0 V	35.0 mA
Reset circuit DC: 24.0 V	35.0 mA
Feedback loop DC: 24.0 V	3.5 mA
Number of output contacts	
Safety contacts (S) instantaneous:	2
Safety contacts (N/O), delayed:	1
Utilisation category in accordance with EN 60947-4-1	
Safety contacts: AC1 at 240 V	$I_{min}: 0.01 A, I_{max}: 5.0 A$ $P_{max}: 1250 VA$
Safety contacts: DC1 at 24 V	$I_{min}: 0.01 A, I_{max}: 5.0 A$ $P_{max}: 125 W$
Safety contacts, delayed: AC1 at 240 V	$I_{min}: 0.01 A, I_{max}: 5.0 A$ $P_{max}: 1250 VA$
Safety contacts, delayed: DC1 at 24 V	$I_{min}: 0.01 A, I_{max}: 5.0 A$ $P_{max}: 125 W$
Utilisation category in accordance with EN 60947-5-1	
Safety contacts: AC15 at 230 V	$I_{max}: 1.5 A$
Safety contacts: DC13 at 24 V (6 cycles/min)	$I_{max}: 2.0 A$
Safety contacts, delayed: AC15 at 230 V	$I_{max}: 2.0 A$
Safety contacts, delayed: DC13 at 24 V (6 cycles/min)	$I_{max}: 4.0 A$
Contact material	AgSnO2 + 0.2 µm Au

Up to PL e of EN ISO 13849-1 PNOZ XV1P

Electrical data	
External contact fuse protection ($I_K = 1 \text{ kA}$) to EN 60947-5-1	
Blow-out fuse, quick	
Safety contacts:	6 A
Safety contacts, delayed:	6 A
Blow-out fuse, slow	
Safety contacts:	4 A
Safety contacts, delayed:	4 A
Circuit breaker 24 VAC/DC, characteristic B/C	
Safety contacts:	4 A
Safety contacts, delayed:	4 A
Max. overall cable resistance R_{lmax} input circuits, reset circuits	
single-channel at U_B DC	100 Ohm
dual-channel without detect. of shorts across contacts at U_B DC	150 Ohm
dual-channel with detect. of shorts across contacts at U_B DC	15 Ohm
Safety-related characteristic data	
PL in accordance with EN ISO 13849-1	
Safety contacts, instantaneous	PL e (Cat. 4)
Safety contacts, delayed <30 s	PL d (Cat. 3)
Safety contacts, delayed ≥ 30 s	PL c (Cat. 1)
Category in accordance with EN 954-1	
Safety contacts, instantaneous	Cat. 4
Safety contacts, delayed <30 s	Cat. 3
Safety contacts, delayed ≥ 30 s	Cat. 1
SIL CL in accordance with EN IEC 62061	
Safety contacts, instantaneous	SIL CL 3
Safety contacts, delayed <30 s	SIL CL 3
Safety contacts, delayed ≥ 30 s	SIL CL 1
PFH in accordance with EN IEC 62061	
Safety contacts, instantaneous	2.31E-09
Safety contacts, delayed <30 s	2.64E-09
Safety contacts, delayed ≥ 30 s	2.87E-09
SIL in accordance with IEC 61511	
Safety contacts, instantaneous	SIL 3
Safety contacts, delayed <30 s	SIL 3
Safety contacts, delayed ≥ 30 s	SIL 2
PFD in accordance with IEC 61511	
Safety contacts, instantaneous	2.03E-06
Safety contacts, delayed <30 s	1.26E-05
Safety contacts, delayed ≥ 30 s	4.64E-05
t_M in years	20
Times	
Switch-on delay	
with automatic reset typ.	300 ms
with automatic reset max.	550 ms
with automatic reset after power on typ.	350 ms
with automatic reset after power on max.	750 ms
on monitored reset with rising edge typ.	30 ms
on monitored reset with rising edge max.	60 ms
Delay-on de-energisation	
with E-STOP typ.	15 ms
with E-STOP max.	30 ms
with power failure typ.	100 ms
with power failure max.	150 ms

Up to PL e of EN ISO 13849-1 PNOZ XV1P

Times	
Recovery time at max. switching frequency 1/s after E-STOP	50 ms +tv
after power failure	300 ms
Repetition accuracy	2 %
Time accuracy	-20 %/+20 %
Waiting period with a monitored reset with rising edge	300 ms
Min. start pulse duration with a monitored reset with rising edge	30 ms
Simultaneity, channel 1 and 2	∞
Supply interruption before de-energisation	20 ms
Environmental data	
EMC	EN 60947-5-1, EN 61000-6-2, EN 61000-6-3
Vibration to EN 60068-2-6	
Frequency	10 - 55 Hz
Amplitude	0.35 mm
Climatic suitability	EN 60068-2-78
Airgap creepage in accordance with EN 60947-1	
Pollution degree	2
Overvoltage category	III
Rated insulation voltage	250 V
Rated impulse withstand voltage	4.0 kV
Ambient temperature	-10 - 55 °C
Storage temperature	-40 - 85 °C
Protection type	
Mounting (e.g. cabinet)	IP54
Housing	IP40
Terminals	IP20
Mechanical data	
Housing material	
Housing	PPO UL 94 V0
Front	ABS UL 94 V0
Cross section of external conductors with screw terminals	
1 core flexible	0.25 - 2.50 mm ² , 24 - 12 AWG Order no.: 777601, 777602
2 core, same cross section, flexible:	
with crimp connectors, without insulating sleeve	0.25 - 1.00 mm ² , 24 - 16 AWG Order no.: 777601, 777602
without crimp connectors or with TWIN crimp connectors	0.20 - 1.50 mm ² , 24 - 16 AWG Order no.: 777601, 777602
Torque setting with screw terminals	0.50 Nm Order no.: 777601, 777602
Cross section of external conductors with spring-loaded terminals: Flexible with/without crimp connectors	0.20 - 1.50 mm ² , 24 - 16 AWG Order no.: 787601, 787602
Spring-loaded terminals: Terminal points per connection	2 Order no.: 787601, 787602
Stripping length	8 mm Order no.: 787601, 787602
Dimensions	
Height	101.0 mm Order no.: 787601, 787602 94.0 mm Order no.: 777601, 777602
Width	22.5 mm
Depth	121.0 mm
Weight	225 g Order no.: 787601, 787602 230 g Order no.: 777601, 777602

The standards current on **2003-09** apply.

Up to PL e of EN ISO 13849-1 PNOZ XV1P

Conventional thermal current

I_{th} (A) at U_B DC	
1 contact	5.00 A
2 contacts	3.70 A
3 contacts	3.00 A

Order reference

Type	Features	Terminals	Order no.
PNOZ XV1P	24 VDC	3 s selectable	Screw terminals 777 601
PNOZ XV1P C	24 VDC	3 s selectable	Spring-loaded terminals 787 601
PNOZ XV1P	24 VDC	30 s selectable	Screw terminals 777 602
PNOZ XV1P C	24 VDC	30 s selectable	Spring-loaded terminals 787 602