

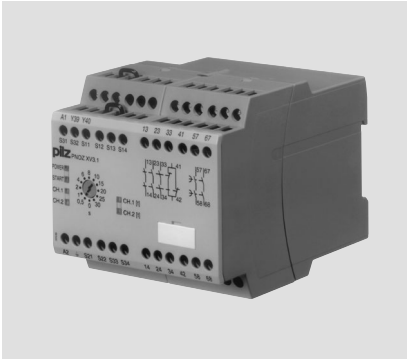



## Up to Category 4, EN 954-1 PNOZ XV3.1



Safety relay for monitoring E-STOP pushbuttons and safety gates.

### Approvals

PNOZ XV3.1	
	◆
	◆
	◆

### Unit features

- ▶ Positive-guided relay outputs:
  - 3 safety contacts (N/O), instantaneous
  - 2 safety contacts (N/O), delay-on de-energisation
  - 1 auxiliary contact (N/C), instantaneous
- ▶ Connection options for:
  - E-STOP pushbutton
  - Safety gate limit switch
  - Reset button
- ▶ Delay-on de-energisation, fixed or adjustable
- ▶ Delay time can be cancelled via reset button
- ▶ LED indicator for:
  - Switch status channel 1/2
  - Supply voltage
  - Reset circuit
- ▶ See order reference for unit types

### Unit description

The safety relay meets the requirements of EN 60947-5-1, EN 60204-1 and VDE 0113-1 and may be used in applications with

- ▶ E-STOP pushbuttons

### ▶ Safety gates

The max. category the safety contacts can achieve in accordance with EN 954-1 is stated in the technical details.

### Safety features

The relay meets the following safety requirements:

- ▶ The circuit is redundant with built-in self-monitoring.
- ▶ The safety function remains effective in the case of a component failure.
- ▶ The correct opening and closing of the safety function relays is tested automatically in each on-off cycle.
- ▶ The transformer is short circuit-proof. An electronic fuse is used on a DC supply.

### Block diagram

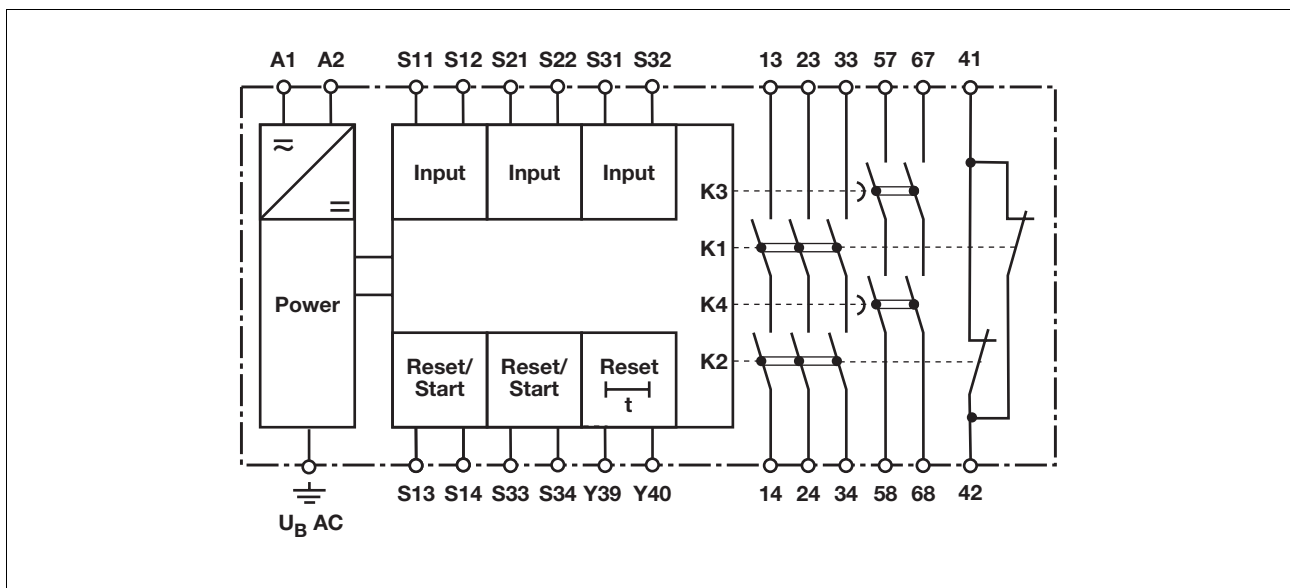

## Up to Category 4, EN 954-1 PNOZ XV3.1

### Function description

- ▶ Single-channel operation: no redundancy in the input circuit, earth faults in the reset circuit are detected.
- ▶ Dual-channel operation with detection of shorts across contacts: redundant input circuit, detects
  - earth faults in the reset and input circuit,
  - short circuits in the input circuit and, with a monitored reset, in the reset circuit too,
  - shorts between contacts in the input circuit.
- ▶ Automatic start: Unit is active once the input circuit has been closed.
- ▶ Monitored reset: Unit is active once the input circuit is closed and once the reset circuit is closed after the waiting period has elapsed (see technical details).
- ▶ Increase in the number of available contacts by connecting contact expansion modules or external contactors/relays.

### Timing diagram

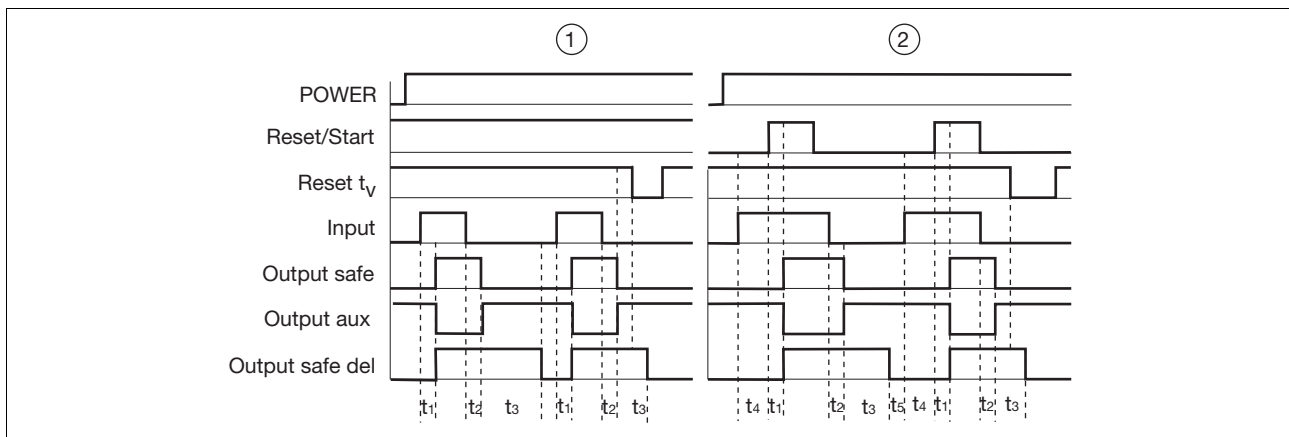

### Key

- ▶ Power: Supply voltage
- ▶ Reset/start: Reset circuit S13-S14, S33-S34
- ▶ Input: Input circuits S11-S12, S21-S22, S31-S32
- ▶ Output safe: Safety contacts, instantaneous 13-14, 23-24, 33-34
- ▶ Output safe del: Safety contacts, delayed 57-58, 67-68
- ▶ Output aux: Auxiliary contacts 41-42
- ▶ ①: Automatic reset
- ▶ ②: Monitored reset
- ▶  $t_1$ : Switch-on delay
- ▶  $t_2$ : Delay-on de-energisation
- ▶  $t_3$ : Delay time
- ▶  $t_4$ : Waiting period
- ▶  $t_5$ : Recovery time

### Wiring

#### Please note:

- ▶ Information given in the “Technical details” must be followed.
- ▶ Outputs 13-14, 23-24, 33-34 are instantaneous safety contacts, outputs 57-58, 67-68 are delay-on de-energisation safety contacts, output 41-42 is an instantaneous auxiliary contact (e.g. for display).
- ▶ To prevent contact welding, a fuse should be connected before the output contacts (see technical details).
- ▶ Calculation of the max. cable runs  $l_{max}$  in the input circuit:

$$l_{max} = \frac{R_{lmax}}{R_l / km}$$

$R_{lmax}$  = max. overall cable resistance (see technical details)

$R_l / km$  = cable resistance/km

- ▶ Use copper wire that can withstand 60/75 °C.
- ▶ Sufficient fuse protection must be provided on all output contacts with capacitive and inductive loads.

## Up to Category 4, EN 954-1 PNOZ XV3.1

### Preparing for operation

#### ► Supply voltage

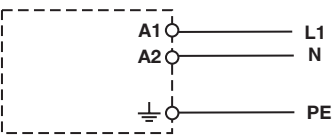
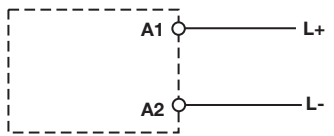
Supply voltage	AC	DC
		

#### ► Input circuit

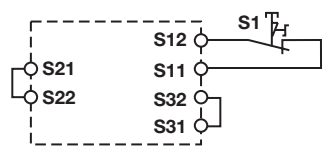
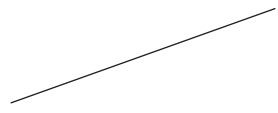
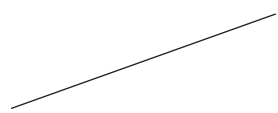
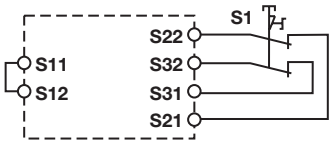
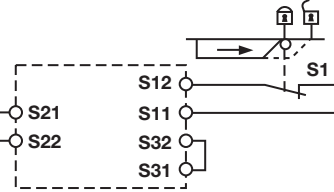
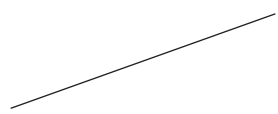
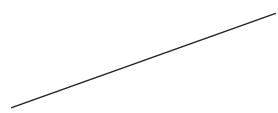
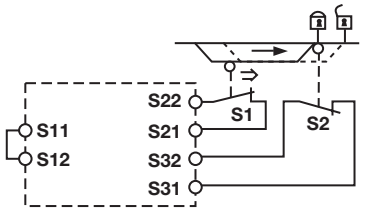
Input circuit	Single-channel	Dual-channel
E-STOP <b>without</b> detection of shorts across contacts		
E-STOP <b>with</b> detection of shorts across contacts		
Safety gate <b>without</b> detection of shorts across contacts		
Safety gate <b>with</b> detection of shorts across contacts		

## Up to Category 4, EN 954-1 PNOZ XV3.1

### ▶ Reset circuit

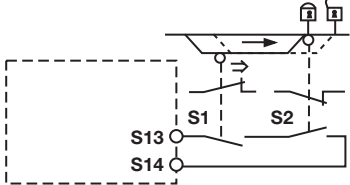
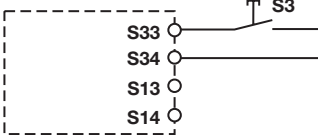
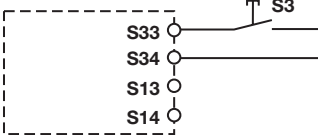
Reset circuit	E-STOP wiring, safety gate	Safety gate (dual-channel)
Automatic reset		
Monitored reset		

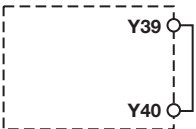
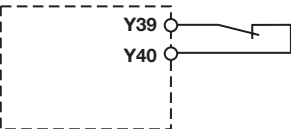

### ▶ Reset delay time

Reset	Without reset	With reset
Link or N/C contact		

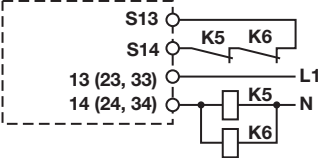
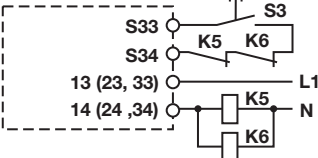
### ▶ Feedback loop

Feedback loop	Automatic reset	Monitored reset
Contacts from external contactors		

### ▶ Key

S1/S2	E-STOP/safety gate switch
S3	Reset button
	Switch operated
	Gate open
	Gate closed

## Up to Category 4, EN 954-1 PNOZ XV3.1

### Terminal configuration

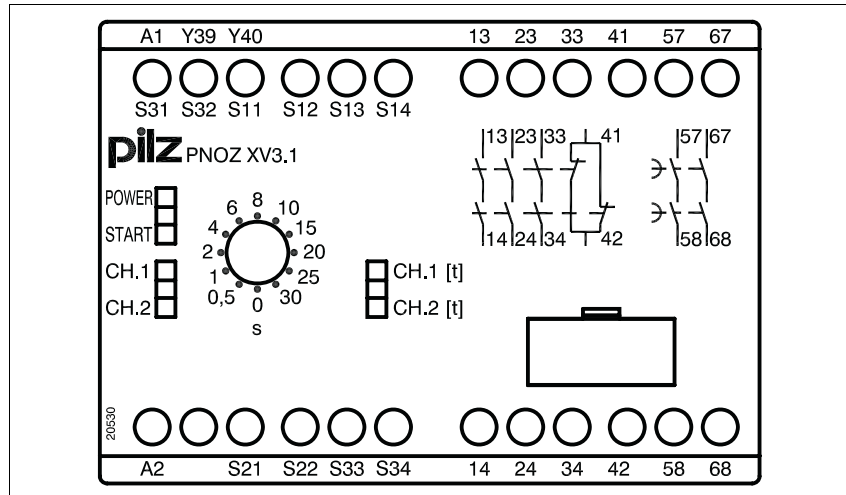

### Installation

- ▶ The safety relay should be installed in a control cabinet with a protection type of at least IP54.
- ▶ Use the notch on the rear of the unit to attach it to a DIN rail.
- ▶ Ensure the unit is mounted securely on a vertical DIN rail (35 mm) by using a fixing element (e.g. retaining bracket or an end angle).

### Dimensions

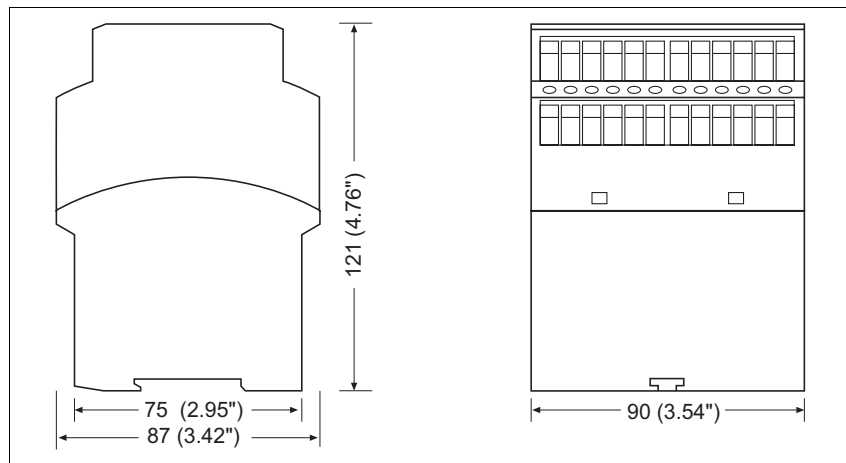

## Up to Category 4, EN 954-1 PNOZ XV3.1

### Notice

This data sheet is only intended for use during configuration. For installation and operation, please refer to the operating instructions supplied with the unit.

### Service life graph

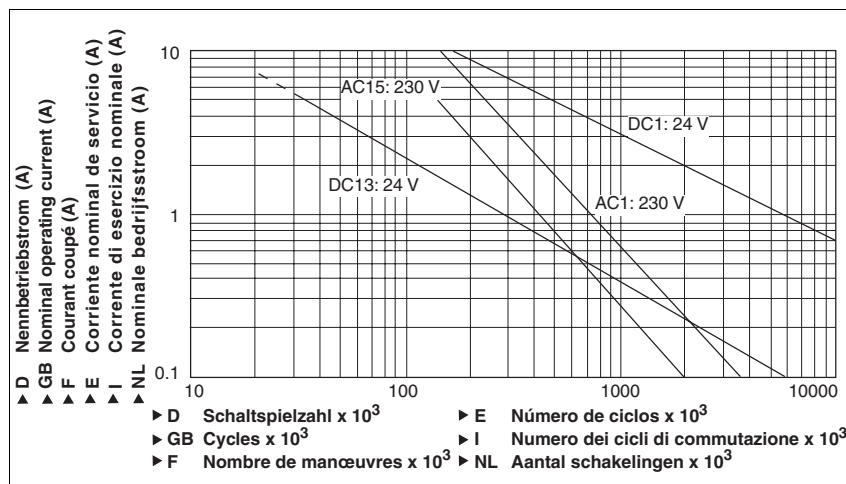

### Technical details

#### Electrical data

Supply voltage	
Supply voltage U <sub>B</sub> DC	<b>24 V</b>
Supply voltage U <sub>B</sub> AC/DC	<b>24 - 240 V</b>
Voltage tolerance	<b>-15 %/+10 %</b>
Power consumption at U <sub>B</sub> AC	<b>8.5 VA</b> Order no.: 774610, 774612, 774618
Power consumption at U <sub>B</sub> DC	<b>4.5 W</b> Order no.: 774530, 774532, 774534, 774538 <b>5.0 W</b> Order no.: 774610, 774612, 774618
Frequency range AC	<b>50 - 60 Hz</b>
Residual ripple DC	<b>160 %</b>
Voltage and current at	
Input circuit DC: <b>24.0 V</b>	<b>40.0 mA</b> Order no.: 774610, 774612, 774618 <b>50.0 mA</b> Order no.: 774530, 774532, 774534, 774538
Reset circuit DC: <b>24.0 V</b>	<b>40.0 mA</b>
Feedback loop DC: <b>24.0 V</b>	<b>3.1 mA</b>
Number of output contacts	
Safety contacts (S) instantaneous:	<b>3</b>
Safety contacts (N/O), delayed:	<b>2</b>
Auxiliary contacts (N/C):	<b>1</b>
Category of output contacts in accordance with <b>EN 954-1</b> , <b>EN ISO 13849-1</b>	
Safety contacts (S) instantaneous:	<b>4</b>
Delay time <30 s	<b>3</b>
Delay time ≥30 s	<b>1</b> Order no.: 774530, 774538, 774610, 774618

## Up to Category 4, EN 954-1 PNOZ XV3.1

### Electrical data

Utilisation category in accordance with <b>EN 60947-4-1</b>	
Safety contacts: AC1 at <b>240 V</b>	$I_{min}$ : <b>0.01 A</b> , $I_{max}$ : <b>8.0 A</b> $P_{max}$ : <b>2000 VA</b>
Safety contacts: DC1 at <b>24 V</b>	$I_{min}$ : <b>0.01 A</b> , $I_{max}$ : <b>8.0 A</b> $P_{max}$ : <b>200 W</b>
Safety contacts, delayed: AC1 at <b>240 V</b>	$I_{min}$ : <b>0.01 A</b> , $I_{max}$ : <b>8.0 A</b> $P_{max}$ : <b>2000 VA</b>
Safety contacts, delayed: DC1 at <b>24 V</b>	$I_{min}$ : <b>0.01 A</b> , $I_{max}$ : <b>8.0 A</b> $P_{max}$ : <b>200 W</b>
Auxiliary contacts: AC1 at <b>240 V</b>	$I_{min}$ : <b>0.01 A</b> , $I_{max}$ : <b>8.0 A</b> $P_{max}$ : <b>2000 VA</b>
Auxiliary contacts: DC1 at <b>24 V</b>	$I_{min}$ : <b>0.01 A</b> , $I_{max}$ : <b>8.0 A</b> $P_{max}$ : <b>200 W</b>
Utilisation category in accordance with <b>EN 60947-5-1</b>	
Safety contacts: AC15 at <b>230 V</b>	$I_{max}$ : <b>5.0 A</b>
Safety contacts: DC13 at <b>24 V</b> (6 cycles/min)	$I_{max}$ : <b>7.0 A</b>
Safety contacts, delayed: AC15 at <b>230 V</b>	$I_{max}$ : <b>5.0 A</b>
Safety contacts, delayed: DC13 at <b>24 V</b> (6 cycles/min)	$I_{max}$ : <b>7.0 A</b>
Auxiliary contacts: AC15 at <b>230 V</b>	$I_{max}$ : <b>5.0 A</b>
Safety contacts, delayed: DC13 at <b>24 V</b> (6 cycles/min)	$I_{max}$ : <b>7.0 A</b>
Contact material	<b>AgSnO<sub>2</sub> + 0.2 µm Au</b>
External contact fuse protection ( $I_K = 1$ kA) to <b>EN 60947-5-1</b>	
Blow-out fuse, quick	
Safety contacts:	<b>10 A</b>
Safety contacts, delayed:	<b>10 A</b>
Auxiliary contacts:	<b>10 A</b>
Blow-out fuse, slow	
Safety contacts:	<b>6 A</b>
Safety contacts, delayed:	<b>6 A</b>
Auxiliary contacts:	<b>6 A</b>
Circuit breaker 24 VAC/DC, characteristic B/C	
Safety contacts:	<b>6 A</b>
Safety contacts, delayed:	<b>6 A</b>
Auxiliary contacts:	<b>6 A</b>
Max. overall cable resistance $R_{lmax}$ input circuits, reset circuits	
single-channel at $U_B$ DC	<b>100 Ohm</b> Order no.: 774530, 774532, 774534, 774538 <b>150 Ohm</b> Order no.: 774610, 774612, 774618
single-channel at $U_B$ AC	<b>150 Ohm</b> Order no.: 774610, 774612, 774618
dual-channel with detect. of shorts across contacts at $U_B$ DC	<b>10 Ohm</b> Order no.: 774530, 774532, 774534, 774538 <b>20 Ohm</b> Order no.: 774610, 774612, 774618
dual-channel with detect. of shorts across contacts at $U_B$ AC	<b>20 Ohm</b> Order no.: 774610, 774612, 774618
<b>Times</b>	
Switch-on delay	
with automatic reset typ.	<b>400 ms</b>
with automatic reset max.	<b>550 ms</b> Order no.: 774610, 774612, 774618 <b>850 ms</b> Order no.: 774530, 774532, 774534, 774538
with automatic reset after power on typ.	<b>400 ms</b> Order no.: 774530, 774532, 774534, 774538 <b>625 ms</b> Order no.: 774610, 774612, 774618
with automatic reset after power on max.	<b>870 ms</b>
on monitored reset with rising edge typ.	<b>35 ms</b> Order no.: 774610, 774612, 774618 <b>40 ms</b> Order no.: 774530, 774532, 774534, 774538
on monitored reset with rising edge max.	<b>60 ms</b> Order no.: 774610, 774612, 774618 <b>70 ms</b> Order no.: 774530, 774532, 774534, 774538

## Up to Category 4, EN 954-1 PNOZ XV3.1

Times	
Delay-on de-energisation	
with E-STOP typ.	<b>15 ms</b>
with E-STOP max.	<b>30 ms</b>
with power failure typ.	<b>110 ms</b> Order no.: 774530, 774532, 774534, 774538
with power failure max.	<b>150 ms</b> Order no.: 774530, 774532, 774534, 774538
with power failure typ. $U_B$ AC/DC: <b>24 V</b> Order no.: 774610, 774612, 774618	<b>90 ms</b> Order no.: 774610, 774612, 774618
with power failure max. $U_B$ AC/DC: <b>24 V</b> Order no.: 774610, 774612, 774618	<b>250 ms</b> Order no.: 774610, 774612, 774618
with power failure typ. $U_B$ AC : <b>240 V</b>	<b>815 ms</b> Order no.: 774610, 774612, 774618
with power failure max. $U_B$ AC : <b>240 V</b>	<b>1900 ms</b> Order no.: 774610, 774612, 774618
Recovery time at max. switching frequency 1/s after E-STOP	<b>50 ms +tv</b>
after power failure	<b>200 ms</b> Order no.: 774530, 774532, 774534, 774538
after power failure on universal power supply	<b>2000 ms</b> Order no.: 774610, 774612, 774618
Delay time $t_V$ : selectable	<b>0,00 s; 0,50 s; 1,00 s; 2,00 s; 4,00 s; 6,00 s; 8,00 s; 10,00 s; 15,00 s; 20,00 s; 25,00 s; 30,00 s</b> Order no.: 774530 <b>0,10 s; 0,20 s; 0,30 s; 0,40 s; 0,50 s; 0,60 s; 0,70 s; 0,80 s; 1,00 s; 1,50 s; 2,00 s; 3,00 s</b> Order no.: 774532 <b>0,00 s; 5,00 s; 10,00 s; 20,00 s; 40,00 s; 60,00 s; 80,00 s; 100,00 s; 150,00 s; 200,00 s; 250,00 s; 300,00 s</b> Order no.: 774538 <b>0,00 s; 0,50 s; 1,00 s; 2,00 s; 4,00 s; 6,00 s; 8,00 s; 10,00 s; 15,00 s; 20,00 s; 25,00 s; 30,00 s</b> Order no.: 774610 <b>0,10 s; 0,20 s; 0,30 s; 0,40 s; 0,50 s; 0,60 s; 0,70 s; 0,80 s; 1,00 s; 1,50 s; 2,00 s; 3,00 s</b> Order no.: 774612 <b>0,00 s; 5,00 s; 10,00 s; 20,00 s; 40,00 s; 60,00 s; 80,00 s; 100,00 s; 150,00 s; 200,00 s; 250,00 s; 300,00 s</b> Order no.: 774618
Delay time $t_V$ : fixed	<b>0.50 s</b> Order no.: 774534
Repetition accuracy	<b>2 %</b>
Time accuracy	<b>-15% / +15% +50 ms</b>
Waiting period with a monitored reset	
with rising edge	<b>300 ms</b>
Min. start pulse duration with a monitored reset	
with rising edge	<b>30 ms</b>
Simultaneity, channel 1 and 2	$\infty$
Supply interruption before de-energisation	<b>20 ms</b>
Environmental data	
EMC	<b>EN 60947-5-1, EN 61000-6-2, EN 61000-6-4</b>
Vibration to <b>EN 60068-2-6</b>	
Frequency	<b>10 - 55 Hz</b>
Amplitude	<b>0.35 mm</b>
Climatic suitability	<b>EN 60068-2-78</b>
Airgap creepage in accordance with <b>EN 60947-1</b>	
Pollution degree	<b>2</b>
Rated insulation voltage	<b>250 V</b>
Rated impulse withstand voltage	<b>4.0 kV</b>
Ambient temperature	<b>-10 - 55 °C</b>
Storage temperature	<b>-40 - 85 °C</b>
Protection type	
Mounting (e.g. cabinet)	<b>IP54</b>
Housing	<b>IP40</b>
Terminals	<b>IP20</b>
Mechanical data	
Housing material	
Housing	<b>PPO UL 94 V0</b>
Front	<b>ABS UL 94 V0</b>



## Up to Category 4, EN 954-1 PNOZ XV3.1

Mechanical data	
Cross section of external conductors with screw terminals	
1 core flexible	<b>0.20 - 4.00 mm<sup>2</sup> , 24 - 10 AWG</b> Order no.: 774530, 774532, 774534, 774538, 774610, 774612 <b>0.20 - 4.00 mm<sup>2</sup> , 24 - 10 AWG</b> Order no.: 774618
2 core, same cross section, flexible: with crimp connectors, without insulating sleeve	<b>0.20 - 2.50 mm<sup>2</sup> , 24 - 14 AWG</b> Order no.: 774530, 774532, 774534, 774538, 774610, 774612 <b>0.20 - 2.50 mm<sup>2</sup> , 24 - 14 AWG</b> Order no.: 774618
without crimp connectors or with TWIN crimp connectors	<b>0.20 - 2.50 mm<sup>2</sup> , 24 - 14 AWG</b> Order no.: 774530, 774532, 774534, 774538, 774610, 774612 <b>0.20 - 2.50 mm<sup>2</sup> , 24 - 14 AWG</b> Order no.: 774618
Torque setting with screw terminals	<b>0.60 Nm</b>
Dimensions	
Height	<b>87.0 mm</b>
Width	<b>90.0 mm</b>
Depth	<b>121.0 mm</b>
Weight	<b>520 g</b> Order no.: 774534 <b>530 g</b> Order no.: 774530, 774532, 774538 <b>600 g</b> Order no.: 774610, 774612, 774618

The standards current on **2008-07** apply.

Conventional thermal current		
Number of contacts	$I_{th}$ (A) at $U_B$ DC	$I_{th}$ (A) at $U_B$ AC
1	<b>8.00 A</b>	<b>8.00 A</b> Order no.: 774610, 774612, 774618
2	<b>7.80 A</b>	<b>7.80 A</b> Order no.: 774610, 774612, 774618
3	<b>6.50 A</b>	<b>6.50 A</b> Order no.: 774610, 774612, 774618
4	<b>5.50 A</b>	<b>5.50 A</b> Order no.: 774610, 774612, 774618
5	<b>5.00 A</b>	<b>5.00 A</b> Order no.: 774610, 774612, 774618

Order reference					
Type	Features			Terminals	Order no.
PNOZ XV3.1		24 VDC	30 s selectable	Screw terminals	774 530
PNOZ XV3.1		24 VDC	3 s selectable	Screw terminals	774 532
PNOZ XV3.1		24 VDC	0.5 s fixed	Screw terminals	774 534
PNOZ XV3.1		24 VDC	300 s selectable	Screw terminals	774 538
PNOZ XV3.1	24 - 240 VAC/DC		30 s selectable	Screw terminals	774 610
PNOZ XV3.1	24 - 240 VAC/DC		3 s selectable	Screw terminals	774 612
PNOZ XV3.1	24 - 240 VAC/DC		300 s selectable	Screw terminals	774 618