



Delayed PZE X4V8



Contact expansion module for increasing the number of available contacts

Approvals

PZE X4V8	
	◆
	◆
	◆

Unit features

- ▶ Positive-guided relay outputs:
 - 4 safety contacts (N/O), delay-on de-energisation
- ▶ LED indicator for:
 - Switch status channel 1/2

Unit description

The unit meets the requirements of EN 60947-5-1, EN 60204-1 and VDE 0113-1. The contact expansion module is used to increase the number of instantaneous safety contacts available on a base unit. Base units are all safety relays with feedback loop monitoring. The category that can be achieved in accordance with EN 954-1 and EN ISO 13849-1 depends on the category of the base unit. The contact expansion module may not exceed this. The delay-on de-energisation safety contacts may only be used up to category 3.

Safety features

The unit meets the following safety requirements:

- ▶ The contact expansion module expands an existing circuit. As the output relays are monitored via the base unit's feedback loop, the safety functions on the existing circuit are transferred to the contact expansion module.
- ▶ The safety function remains effective in the case of a component failure.
- ▶ Earth fault in the feedback loop: Detected, depending on the base unit that is used.
- ▶ Earth fault in the input circuit: The output relays de-energise and the safety contacts open.

Block diagram

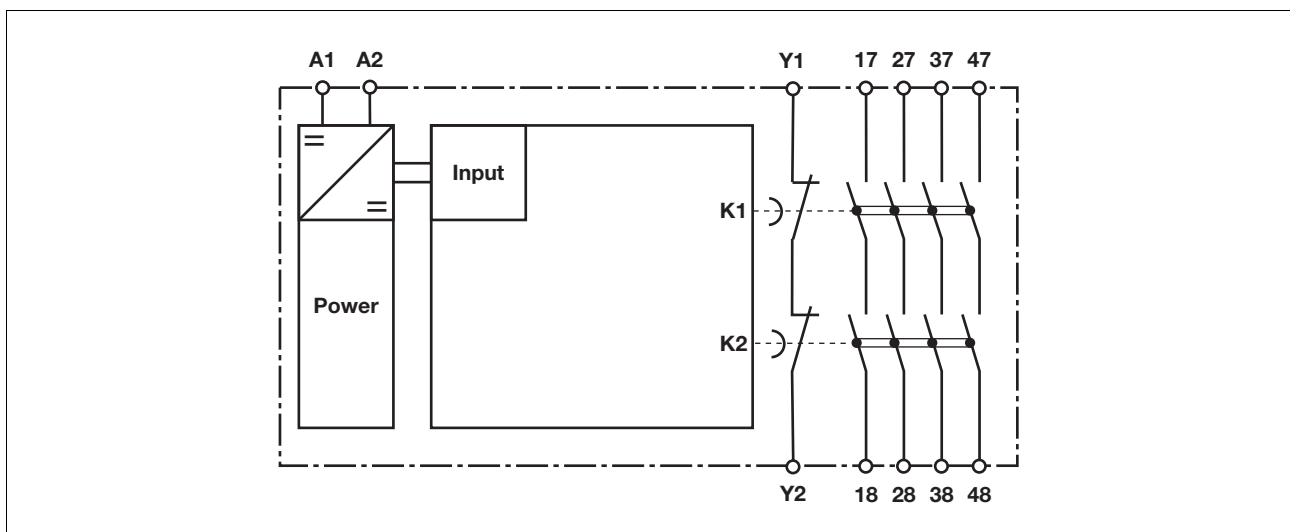

Delayed PZE X4V8

Function description

- ▶ Single-channel operation: one input circuit affects both output relays

Timing diagram

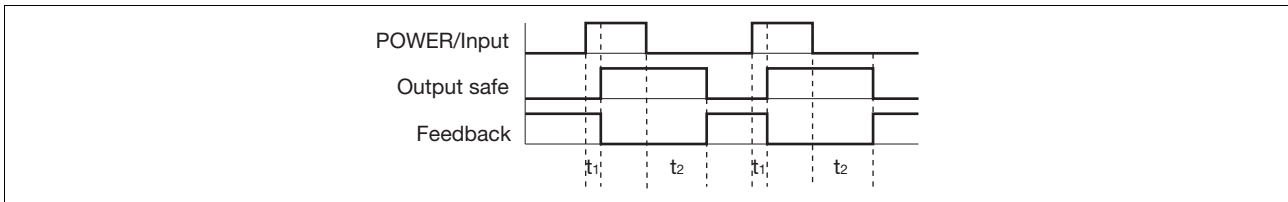

Key

- ▶ Power: Supply voltage
- ▶ Input: Input circuits A1
- ▶ Output safe: Safety contacts 17-18, 27-28, 37-38, 47-48
- ▶ Feedback: Feedback loop Y1-Y2
- ▶ t_1 : Switch-on delay
- ▶ t_2 : Delay-on de-energisation

Wiring

Please note:

- ▶ Information given in the “Technical details” must be followed.
- ▶ Outputs 17-18, 27-28, 37-38, 47-48 are delay-on de-energisation safety contacts.
- ▶ To prevent contact welding, a fuse should be connected before the output contacts (see technical details).
- ▶ Calculation of the max. cable runs l_{max} in the input circuit:

$$l_{max} = \frac{R_{lmax}}{R_l / km}$$

R_{lmax} = max. overall cable resistance (see technical details)

R_l / km = cable resistance/km

- ▶ Use copper wire that can withstand 60/75 °C.
- ▶ Sufficient fuse protection must be provided on all output contacts with capacitive and inductive loads.

Delayed PZE X4V8

Preparing for operation

▶ Supply voltage

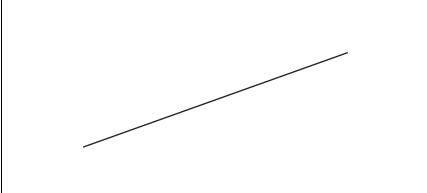
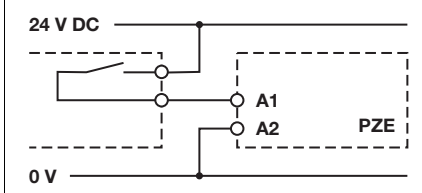
Supply voltage	AC	DC
		

▶ Input circuit

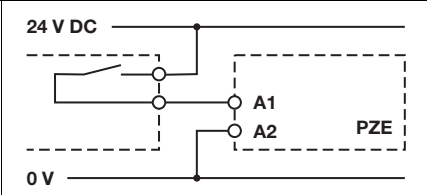
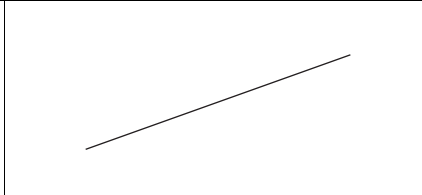
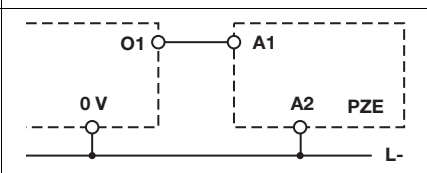
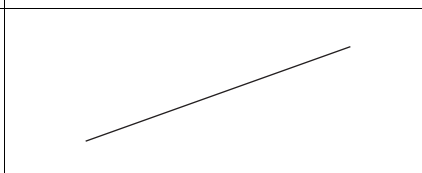
Input circuit	Single-channel	Dual-channel
Base unit: PNOZ X safety relay Driven via safety contacts		
PNOZelog base unit Driven via semiconductor outputs (24 VDC)		

▶ Feedback loop

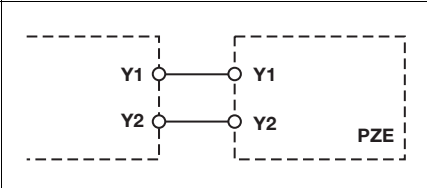
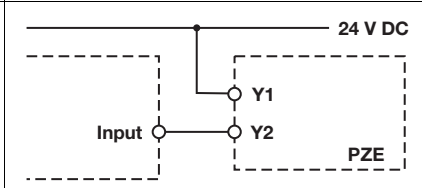
Feedback loop	Automatic reset	Monitored reset
Y1, Y2 and Input are inputs on the base unit; they evaluate the feedback loop		

Delayed PZE X4V8

► Setting the delay time

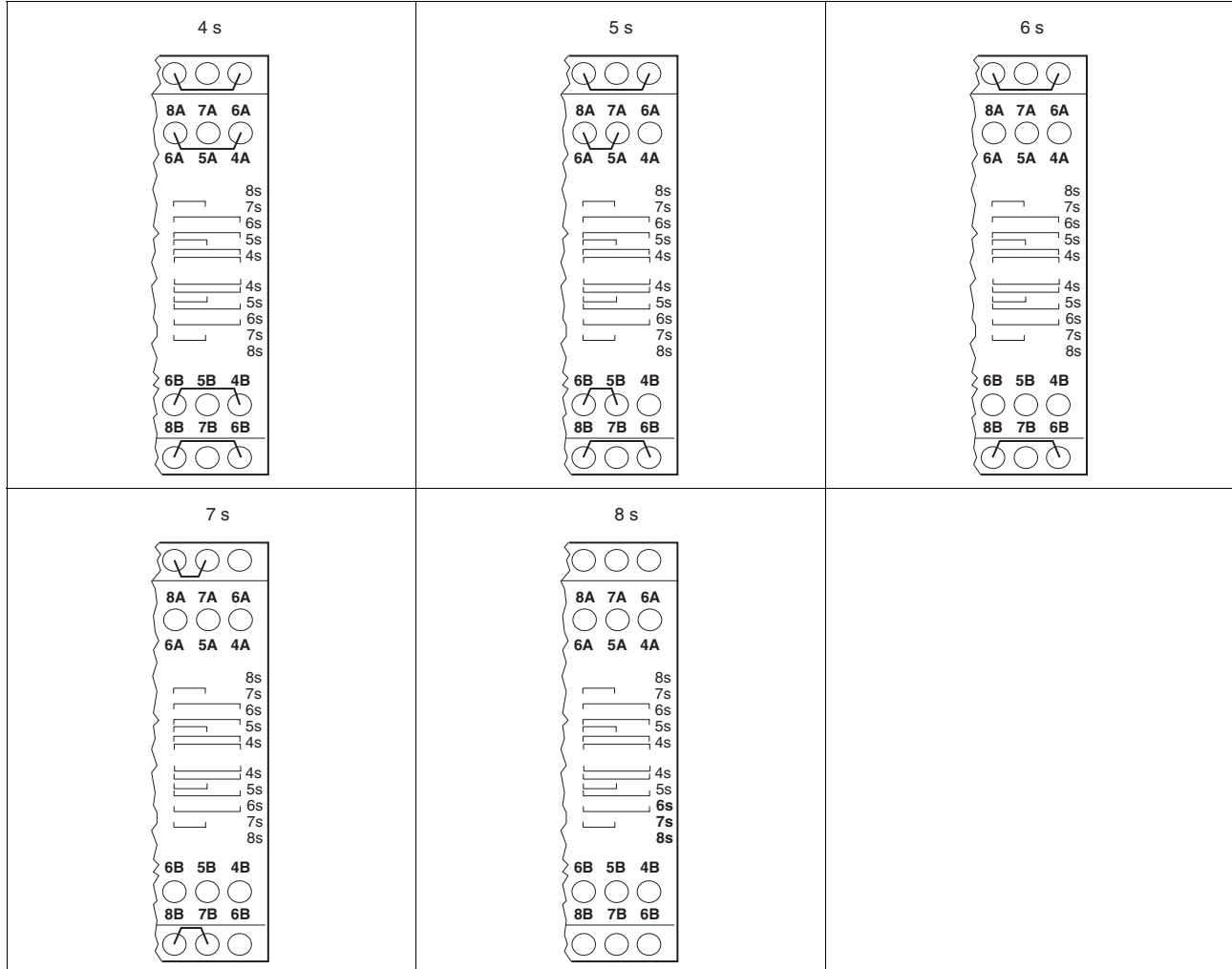

Delayed PZE X4V8

Terminal configuration

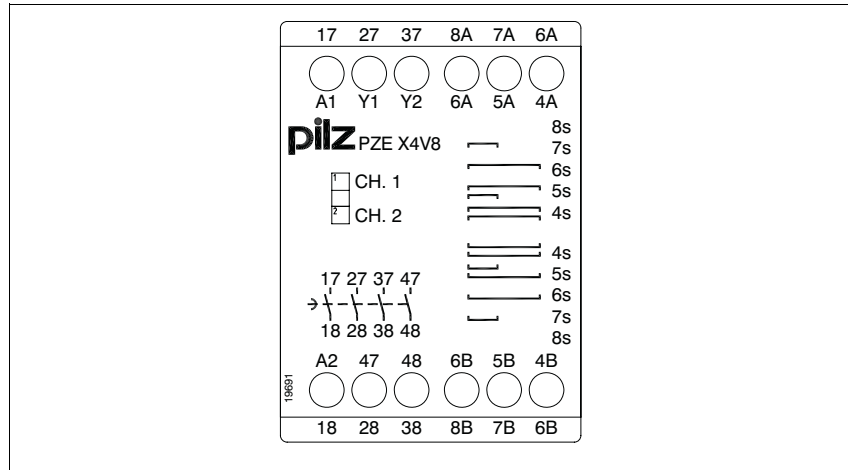

Installation

- ▶ The safety relay should be installed in a control cabinet with a protection type of at least IP54.
- ▶ Use the notch on the rear of the unit to attach it to a DIN rail.
- ▶ Ensure the unit is mounted securely on a vertical DIN rail (35 mm) by using a fixing element (e.g. retaining bracket or an end angle).

Dimensions

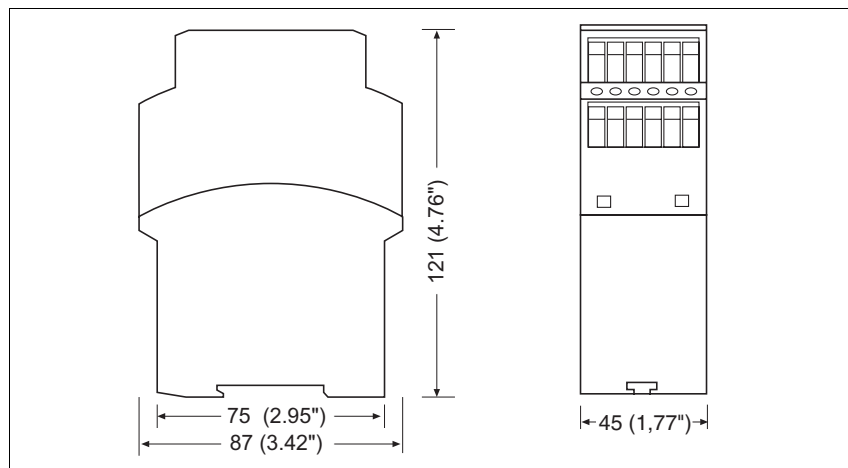

Delayed PZE X4V8

Notice

This data sheet is only intended for use during configuration. For installation and operation, please refer to the operating instructions supplied with the unit.

Service life graph

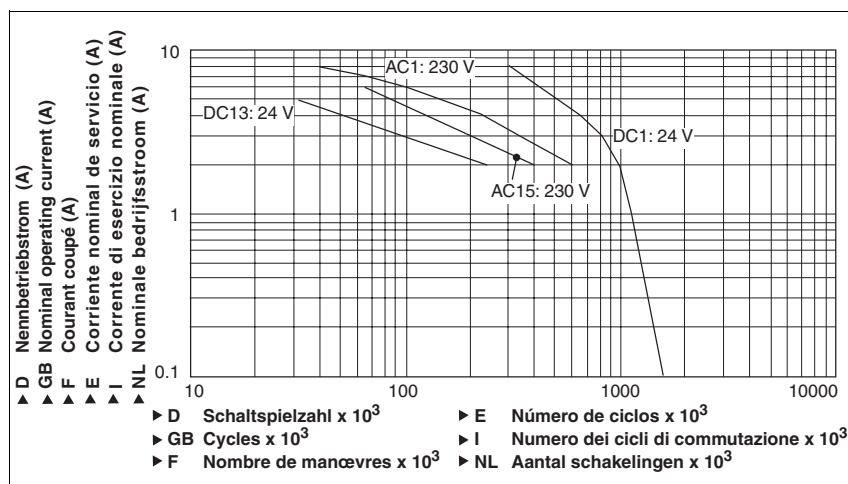

Technical details

Electrical data

Supply voltage	
Supply voltage U_B DC	24 V
Voltage tolerance	-15 %/+10 %
Power consumption at U_B DC	2.5 W
Residual ripple DC	20 %
Voltage and current at	
Input circuit DC: 24.0 V	70.0 mA
Number of output contacts	
Safety contacts (N/O), delayed:	4
Category of output contacts in accordance with EN 954-1, EN ISO 13849-1	
Delay time <30 s	3
Utilisation category in accordance with EN 60947-4-1	
Safety contacts, delayed: AC1 at 240 V	I_{min} : 0.01 A , I_{max} : 5.0 A P_{max} : 1200 VA
Safety contacts, delayed: DC1 at 24 V	I_{min} : 0.01 A , I_{max} : 5.0 A P_{max} : 120 W
Utilisation category in accordance with EN 60947-5-1	
Safety contacts, delayed: AC15 at 230 V	I_{max} : 5.0 A
Safety contacts, delayed: DC13 at 24 V (6 cycles/min)	I_{max} : 4.0 A
Conventional thermal current	5.0 A
Contact material	AgSnO₂ + 0.2 µm Au
External contact fuse protection ($I_K = 1$ kA) to EN 60947-5-1	
Blow-out fuse, quick	
Safety contacts:	6 A
Blow-out fuse, slow	
Safety contacts:	4 A
Circuit breaker 24 VAC/DC, characteristic B/C	
Safety contacts:	4 A
Max. overall cable resistance R_{lmax} per input circuit single-channel at U_B DC	30 Ohm
Times	
Switch-on delay	
with automatic reset after power on typ.	320 ms
with automatic reset after power on max.	500 ms

Delayed PZE X4V8

Times	
Delay time t_V : selectable	4,00 s; 5,00 s; 6,00 s; 7,00 s; 8,00 s Order no.: 774584
Time accuracy	-50 %/+50 %
Supply interruption before de-energisation	20 ms
Environmental data	
EMC	EN 60947-5-1, EN 61000-6-2
Vibration to EN 60068-2-6	
Frequency	10 - 55 Hz
Amplitude	0.35 mm
Climatic suitability	EN 60068-2-78
Airgap creepage in accordance with EN 60947-1	
Pollution degree	2
Rated insulation voltage	250 V
Rated impulse withstand voltage	4.0 kV
Ambient temperature	-10 - 55 °C
Storage temperature	-40 - 85 °C
Protection type	
Mounting (e.g. cabinet)	IP54
Housing	IP40
Terminals	IP20
Mechanical data	
Housing material	
Housing	PPO UL 94 V0
Front	ABS UL 94 V0
Cross section of external conductors with screw terminals	
1 core flexible	0.20 - 4.00 mm ² , 24 - 10 AWG
2 core, same cross section, flexible:	
with crimp connectors, without insulating sleeve	0.20 - 2.50 mm ² , 24 - 14 AWG
without crimp connectors or with TWIN crimp connectors	0.20 - 2.50 mm ² , 24 - 14 AWG
Torque setting with screw terminals	0.60 Nm
Dimensions	
Height	87.0 mm
Width	45.0 mm
Depth	121.0 mm
Weight	350 g

The standards current on **2008-07** apply.

Order reference				
Type	Features		Terminals	Order no.
PZE X4V8	24 VDC	8 s selectable	Screw terminals	774 584